

L:
 CBL-HFD3igMB-4m 4000mm±30mm
 CBL-HFD3igMB-5m 5000mm±30mm
 CBL-HFD3igMB-6m 6000mm±30mm

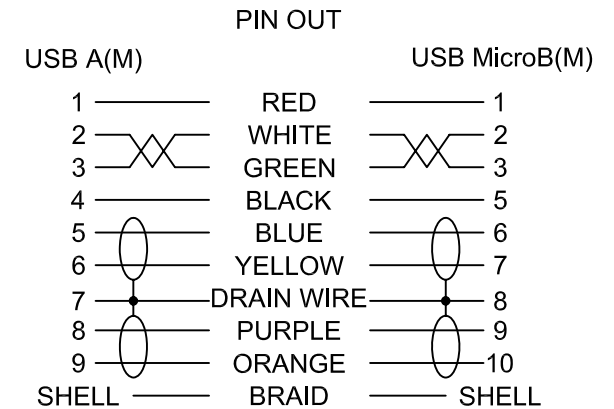

No	MATERIALS LIST:
1.	CABLE:UL20236 (2x(2x28AWG)+2x(2x28AWG)C) OD:7.0mm PUR JACKET COLOR:RED LILAC
2.	CONNECTOR:USB 3.0 A/M, 9P, BLUE INSULATOR SOLDER TYPE, NICKEL PLATED SHELL
3.	CONNECTOR:USB 3.0 MicroB/M, 10P, BLACK INSULATOR SOLDER TYPE, NICKEL PLATED SHELL
4.	ABS ASSEMBLY HOUSING, BLACK COLOR
5.	

Jargy part no.	Client part no.	Approved	SCALE	UNIT
CBL-HFD3igMB-xm				mm
Drawing Name		Drawn	Date	REV.
USB 3.0 A to Micro-B Cable M/M				1.0

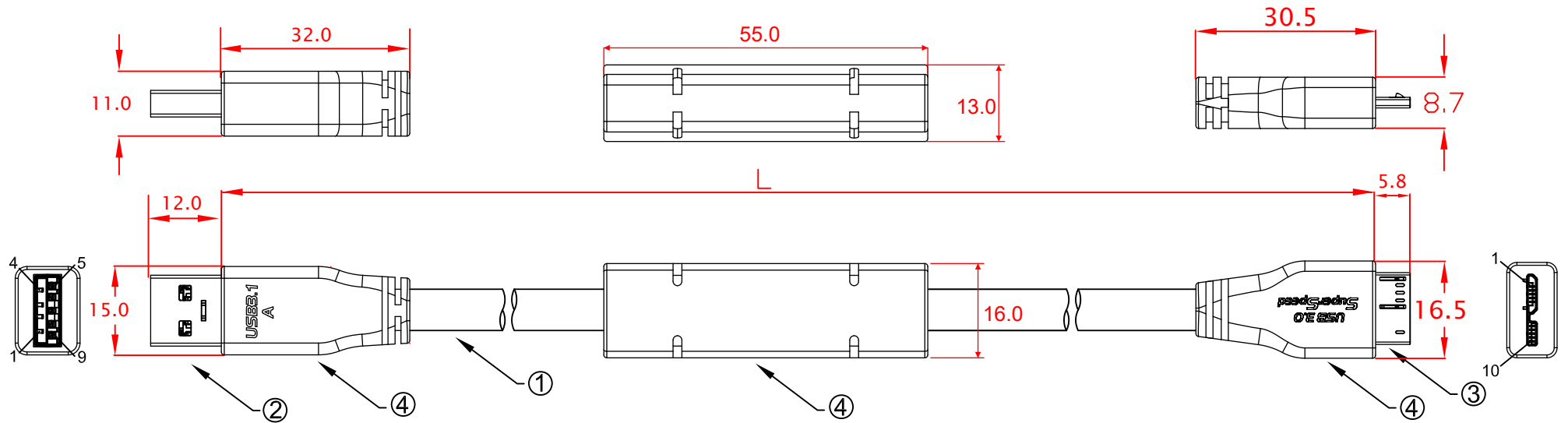

L:
 CBL-HFD3igMB-4m 4000mm±30mm
 CBL-HFD3igMB-5m 5000mm±30mm
 CBL-HFD3igMB-6m 6000mm±30mm

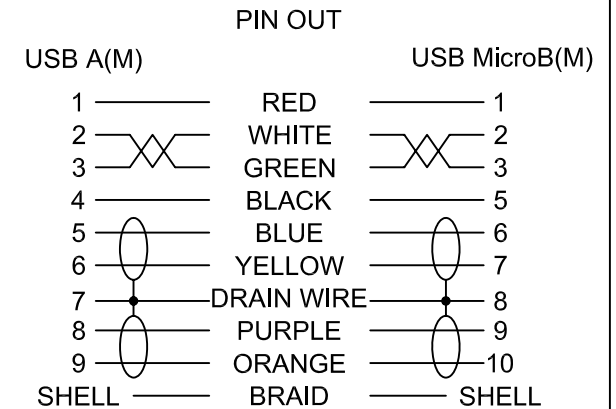

No	MATERIALS LIST:
1.	CABLE:UL20236 (2x(2x28AWG)+2x(2x28AWG)C) OD:7.0mm PUR JACKET COLOR:RED LILAC
2.	CONNECTOR:USB 3.0 A/M, 9P, BLUE INSULATOR SOLDER TYPE, NICKEL PLATED SHELL
3.	CONNECTOR:USB 3.0 MicroB/M, 10P, BLACK INSULATOR SOLDER TYPE, NICKEL PLATED SHELL
4.	PVC MOLDED HOUSING, BLACK COLOR
5.	
6.	

Jargy part no.	Client part no.	Approved	SCALE	UNIT
CBL-HFD3igMB-xm				mm
Drawing Name		Drawn	Date	REV.
USB 3.0 A to MicroB Cable M/M				1.0

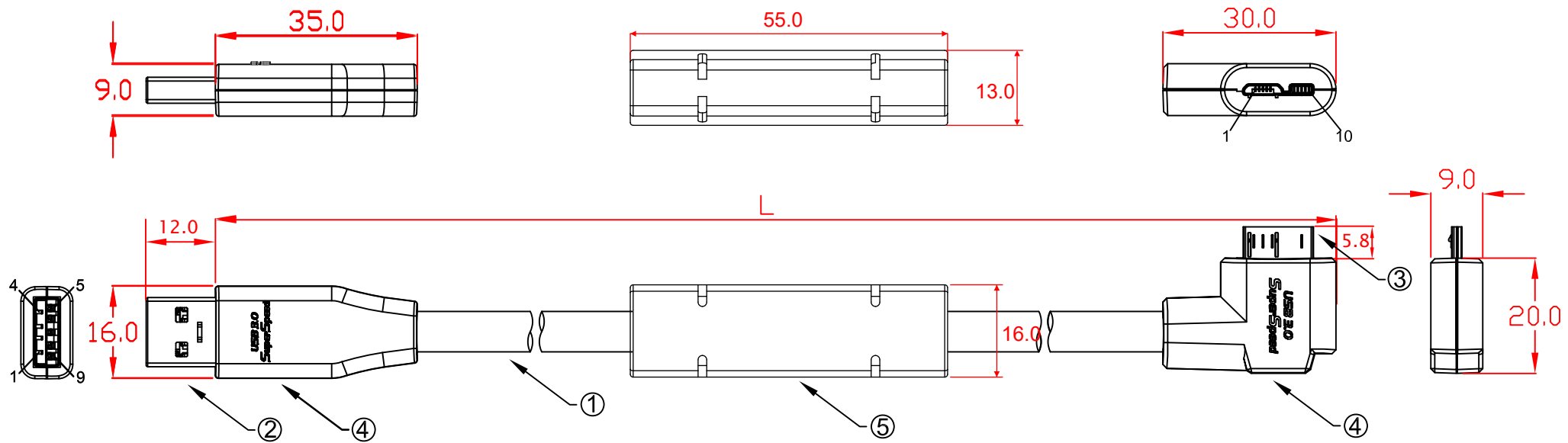

L:
 CBL-HFD3igMB-4mLA 4000mm±30mm
 CBL-HFD3igMB-5mLA 5000mm±30mm
 CBL-HFD3igMB-6mLA 6000mm±30mm

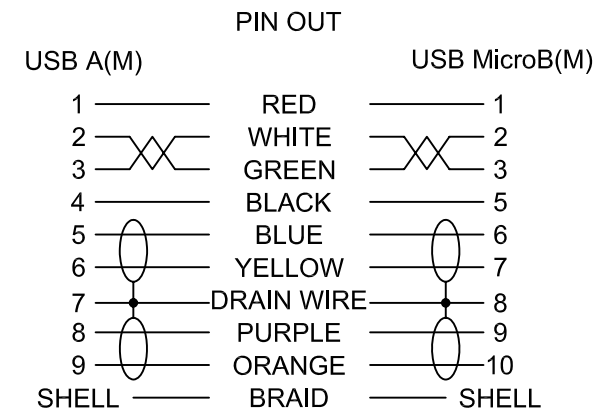

No	MATERIALS LIST:
1.	CABLE:UL20236 (2x(2x28AWG)+2x(2x28AWG)C) OD:7.0mm PUR JACKET COLOR:RED LILAC
2.	CONNECTOR:USB 3.0 A/M, 9P, BLUE INSULATOR SOLDER TYPE, NICKEL PLATED SHELL
3.	CONNECTOR:USB 3.0 MicroB/M, 10P, BLACK INSULATOR SOLDER TYPE, NICKEL PLATED SHELL
4.	ABS ASSEMBLY HOUSING, BLACK COLOR
5.	PVC MOLDED HOUSING, BLACK COLOR

Jargy part no.	Client part no.	Approved	SCALE	UNIT
CBL-HFD3igMB-xmLA				mm
Drawing Name		Drawn	Date	REV.
USB 3.0 A to Micro-B Cable M/M				1.0

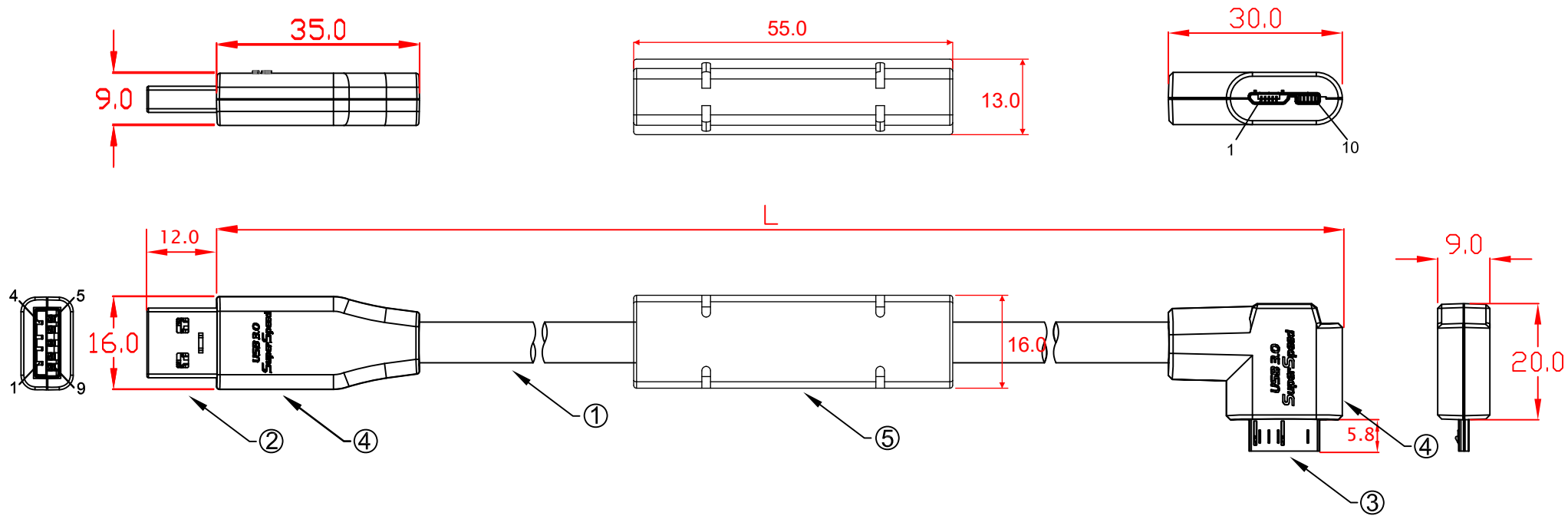

L:
 CBL-HFD3igMB-4mRA 4000mm±30mm
 CBL-HFD3igMB-5mRA 5000mm±30mm
 CBL-HFD3igMB-6mRA 6000mm±30mm

PIN OUT

USB A(M)		USB MicroB(M)	
1 ———	RED	———— 1	
2 —X—X—	WHITE	———— 2	
3 —X—X—	GREEN	———— 3	
4 ———	BLACK	———— 4	
5 ———	BLUE	———— 5	
6 ———	YELLOW	———— 6	
7 —●—	DRAIN WIRE	———— 7	
8 ———	PURPLE	———— 8	
9 ———	ORANGE	———— 9	
SHELL ———	BRAID	———— 10	
		————	SHELL

No	MATERIALS LIST:
1.	CABLE:UL20236 (2x(2x28AWG)+2x(2x28AWG)C) OD:7.0mm PUR JACKET COLOR:RED LILAC
2.	CONNECTOR:USB 3.0 A/M, 9P, BLUE INSULATOR SOLDER TYPE, NICKEL PLATED SHELL
3.	CONNECTOR:USB 3.0 MicroB/M, 10P, BLACK INSULATOR SOLDER TYPE, NICKEL PLATED SHELL
4.	ABS ASSEMBLY HOUSING, BLACK COLOR
5.	PVC MOLDED HOUSING, BLACK COLOR

Jargy part no.	Client part no.	Approved	SCALE	UNIT
CBL-HFD3igMB-xmRA				mm
Drawing Name		Drawn	Date	REV.
USB 3.0 A to Micro-B Cable M/M				1.0

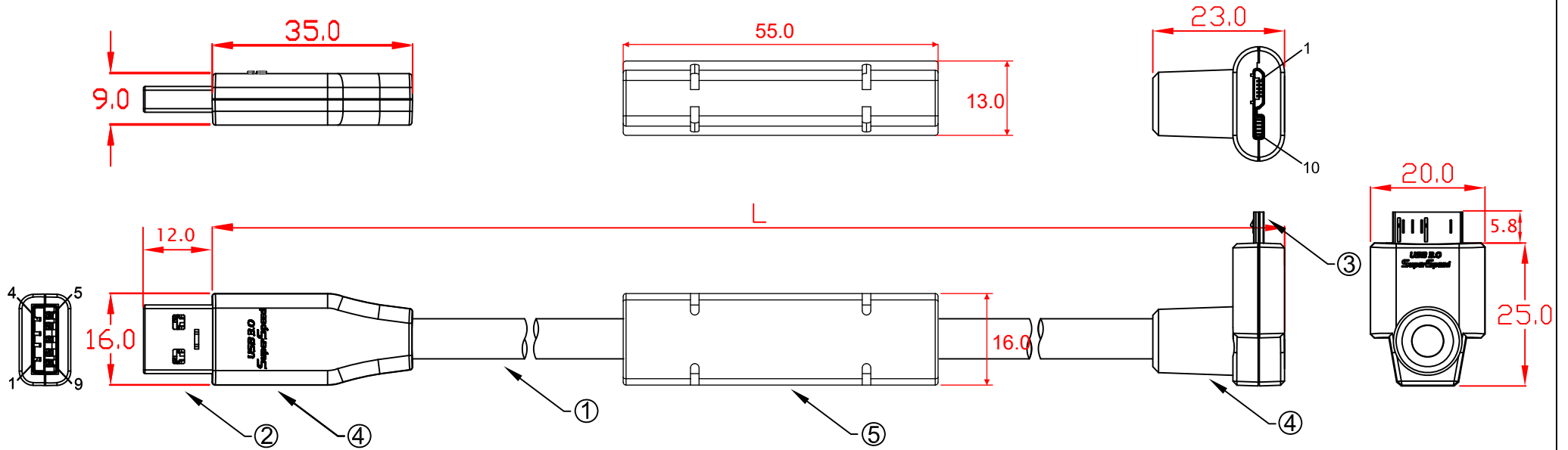

L:
 CBL-HFD3igMB-4mUA 4000mm±30mm
 CBL-HFD3igMB-5mUA 5000mm±30mm
 CBL-HFD3igMB-6mUA 6000mm±30mm

USB A(M)		PIN OUT	USB MicroB(M)	
1	—	RED	—	1
2	⌵	WHITE	⌵	2
3	⌵	GREEN	⌵	3
4	—	BLACK	—	5
5	—	BLUE	—	6
6	⌵	YELLOW	⌵	7
7	—	DRAIN WIRE	—	8
8	⌵	PURPLE	⌵	9
9	⌵	ORANGE	⌵	10
SHELL	—	BRAID	—	SHELL

No	MATERIALS LIST:
1.	CABLE:UL20236 (2x(2x28AWG)+2x(2x28AWG)C) OD:7.0mm PUR JACKET COLOR:RED LILAC
2.	CONNECTOR:USB 3.0 A/M, 9P, BLUE INSULATOR SOLDER TYPE, NICKEL PLATED SHELL
3.	CONNECTOR:USB 3.0 MicroB/M, 10P, BLACK INSULATOR SOLDER TYPE, NICKEL PLATED SHELL
4.	ABS ASSEMBLY HOUSING, BLACK COLOR
5.	PVC MOLDED HOUSING, BLACK COLOR

Jargy part no.	Client part no.	Approved	SCALE	UNIT
CBL-HFD3igMB-xmUA				mm
Drawing Name		Drawn	Date	REV.
USB 3.0 A to Micro-B Cable M/M				1.0

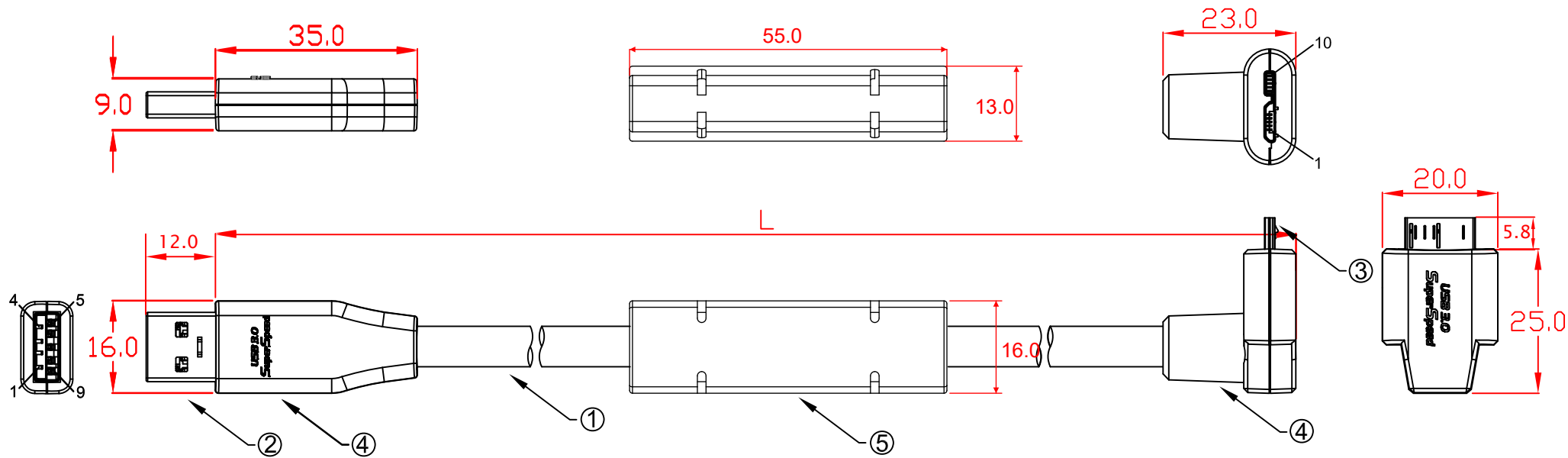

L:
 CBL-HFD3igMB-4mDA 4000mm±30mm
 CBL-HFD3igMB-5mDA 5000mm±30mm
 CBL-HFD3igMB-6mDA 6000mm±30mm

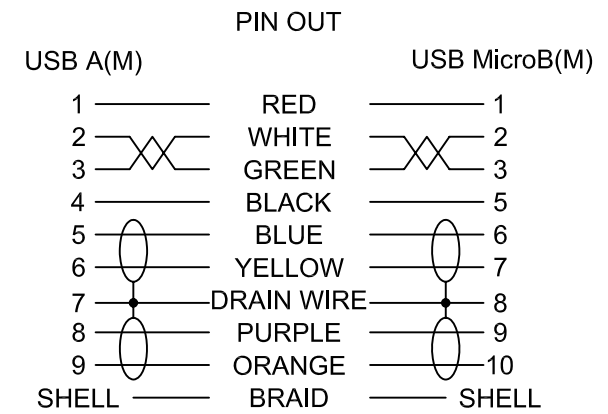

No	MATERIALS LIST:
1.	CABLE:UL20236 (2x(2x28AWG)+2x(2x28AWG)C) OD:7.0mm PUR JACKET COLOR:RED LILAC
2.	CONNECTOR:USB 3.0 A/M, 9P, BLUE INSULATOR SOLDER TYPE, NICKEL PLATED SHELL
3.	CONNECTOR:USB 3.0 MicroB/M, 10P, BLACK INSULATOR SOLDER TYPE, NICKEL PLATED SHELL
4.	ABS ASSEMBLY HOUSING, BLACK COLOR
5.	PVC MOLDED HOUSING, BLACK COLOR

Jargy part no.	Client part no.	Approved	SCALE	UNIT
CBL-HFD3igMB-xmDA				mm
Drawing Name		Drawn	Date	REV.
USB 3.0 A to Micro-B Cable M/M				1.0

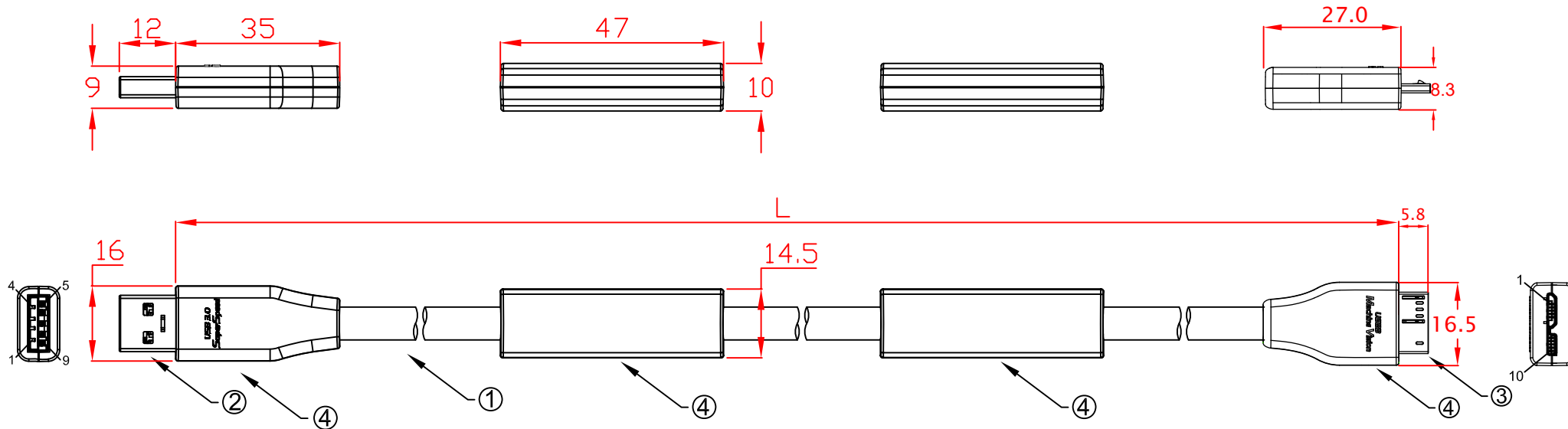

L:
 CBL-HFD3igMB-7m 7000mm±50mm
 CBL-HFD3igMB-8m 8000mm±50mm
 CBL-HFD3igMB-9m 9000mm±50mm

USB A(M)		PIN OUT	USB MicroB(M)	
1	—	RED	1	—
2	—	WHITE	2	—
3	—	GREEN	3	—
4	—	BLACK	5	—
5	—	BLUE	6	—
6	—	YELLOW	7	—
7	—	DRAIN WIRE	8	—
8	—	PURPLE	9	—
9	—	ORANGE	10	—
SHELL	—	BRAID	SHELL	—

No	MATERIALS LIST:
1.	CABLE:UL20236 (2x(2x28AWG)+2x(2x28AWG)C) OD:7.0mm PUR JACKET COLOR:RED LILAC
2.	CONNECTOR:USB 3.0 A/M, 9P, BLUE INSULATOR SOLDER TYPE, NICKEL PLATED SHELL
3.	CONNECTOR:USB 3.0 MicroB/M, 10P, BLACK INSULATOR SOLDER TYPE, NICKEL PLATED SHELL
4.	ABS ASSEMBLY HOUSING, BLACK COLOR

Jargy part no.	Client part no.	Approved	SCALE	UNIT
CBL-HFD3igMB-xm				mm
Drawing Name		Drawn	Date	REV.
USB 3.0 A to Micro-B Cable M/M				1.0

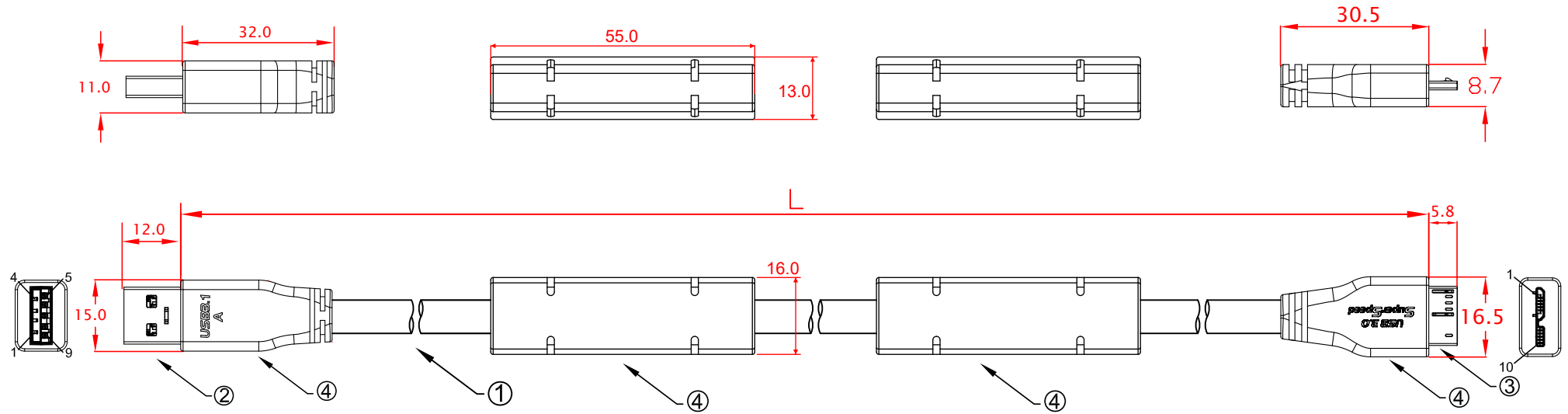

L:
 CBL-HFD3igMB-7m 7000mm±50mm
 CBL-HFD3igMB-8m 8000mm±50mm
 CBL-HFD3igMB-9m 9000mm±50mm

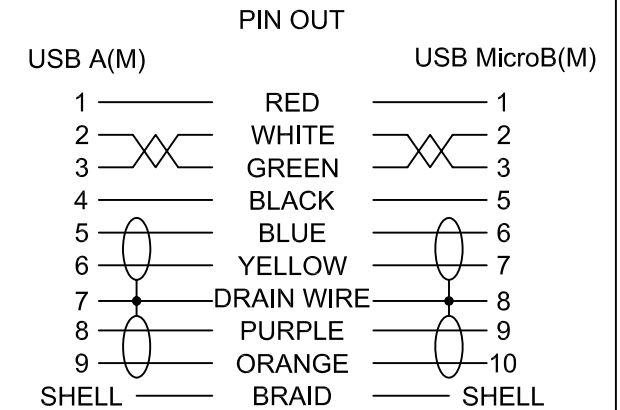

No	MATERIALS LIST:
1.	CABLE:UL20236 (2x(2x28AWG)+2x(2x28AWG)C) OD:7.0mm PUR JACKET COLOR:RED LILAC
2.	CONNECTOR:USB 3.0 A/M, 9P, BLUE INSULATOR SOLDER TYPE, NICKEL PLATED SHELL
3.	CONNECTOR:USB 3.0 MicroB/M, 10P, BLACK INSULATOR SOLDER TYPE, NICKEL PLATED SHELL
4.	PVC MOLDED HOUSING, BLACK COLOR
5.	
6.	

Jargy part no.	Client part no.	Approved	SCALE	UNIT
CBL-HFD3igMB-xm				mm
Drawing Name		Drawn	Date	REV.
USB 3.0 A to MicroB Cable M/M				1.0

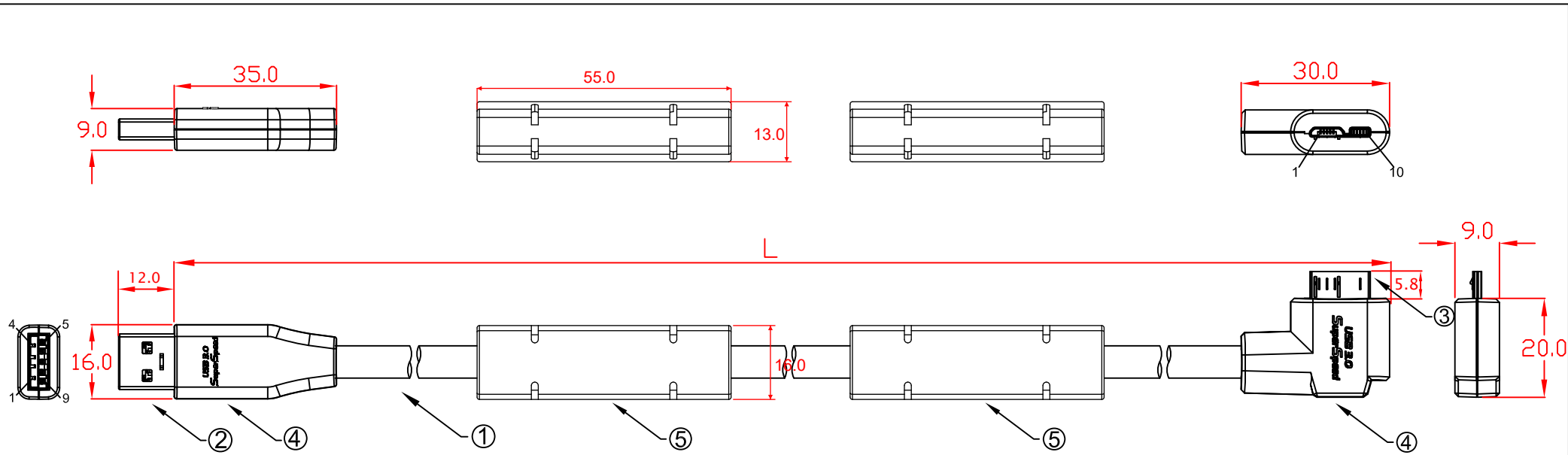

L:
 CBL-HFD3igMB-7mLA 7000mm±50mm
 CBL-HFD3igMB-8mLA 8000mm±50mm
 CBL-HFD3igMB-9mLA 9000mm±50mm

No	MATERIALS LIST:
1.	CABLE:UL20236 (2x(2x28AWG)+2x(2x28AWG)C) OD:7.0mm PUR JACKET COLOR:RED LILAC
2.	CONNECTOR:USB 3.0 A/M, 9P, BLUE INSULATOR SOLDER TYPE, NICKEL PLATED SHELL
3.	CONNECTOR:USB 3.0 MicroB/M, 10P, BLACK INSULATOR SOLDER TYPE, NICKEL PLATED SHELL
4.	ABS ASSEMBLY HOUSING, BLACK COLOR
5.	PVC MOLDED HOUSING, BLACK COLOR

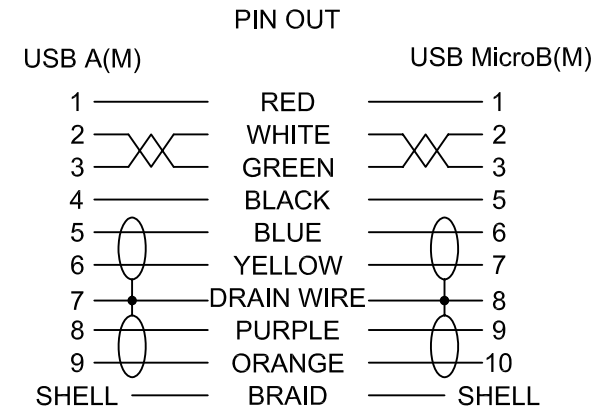

Jargy part no.	Client part no.	Approved	SCALE	UNIT
CBL-HFD3igMB-xmLA				mm
Drawing Name		Drawn	Date	REV.
USB 3.0 A to Micro-B Cable M/M				1.0

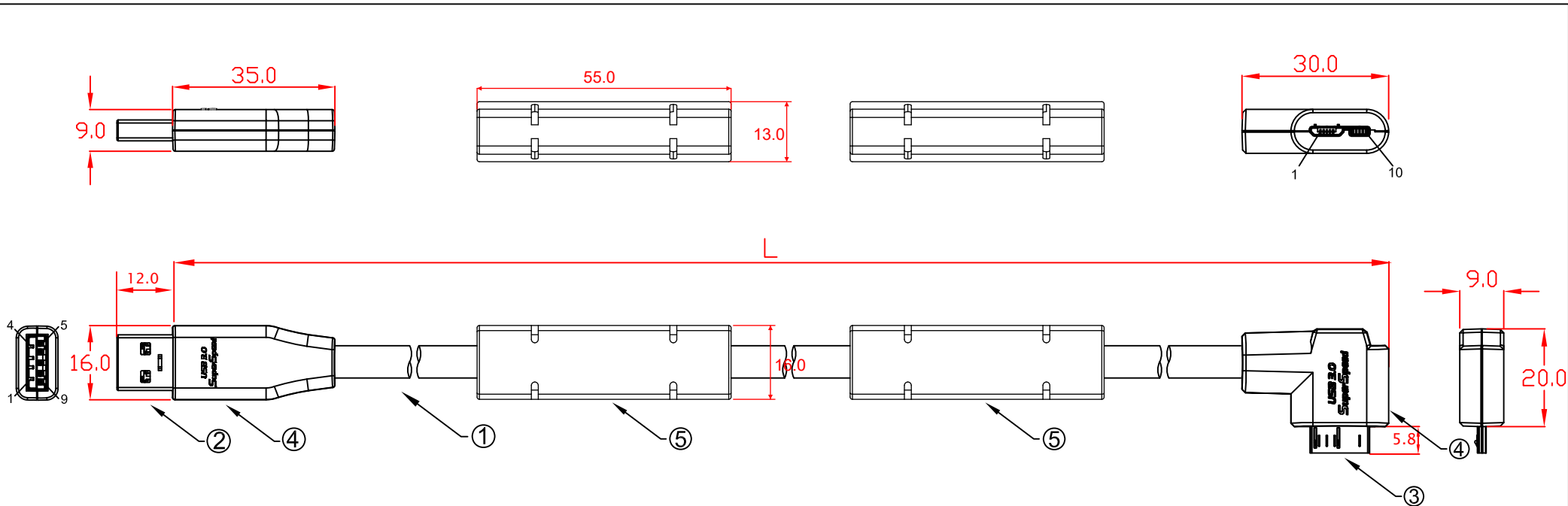

L:
 CBL-HFD3igMB-7mRA 7000mm±50mm
 CBL-HFD3igMB-8mRA 8000mm±50mm
 CBL-HFD3igMB-9mRA 9000mm±50mm

No	MATERIALS LIST:
1.	CABLE:UL20236 (2x(2x28AWG)+2x(2x28AWG)C) OD:7.0mm PUR JACKET COLOR:RED LILAC
2.	CONNECTOR:USB 3.0 A/M, 9P, BLUE INSULATOR SOLDER TYPE, NICKEL PLATED SHELL
3.	CONNECTOR:USB 3.0 MicroB/M, 10P, BLACK INSULATOR SOLDER TYPE, NICKEL PLATED SHELL
4.	ABS ASSEMBLY HOUSING, BLACK COLOR
5.	PVC MOLDED HOUSING, BLACK COLOR

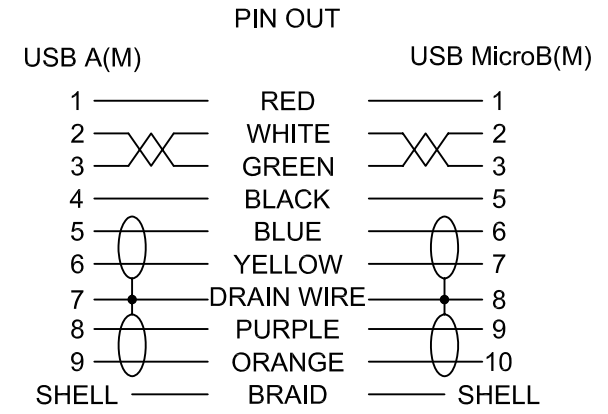

Jargy part no.	Client part no.	Approved	SCALE	UNIT
CBL-HFD3igMB-xmRA				mm
Drawing Name		Drawn	Date	REV.
USB 3.0 A to Micro-B Cable M/M				1.0

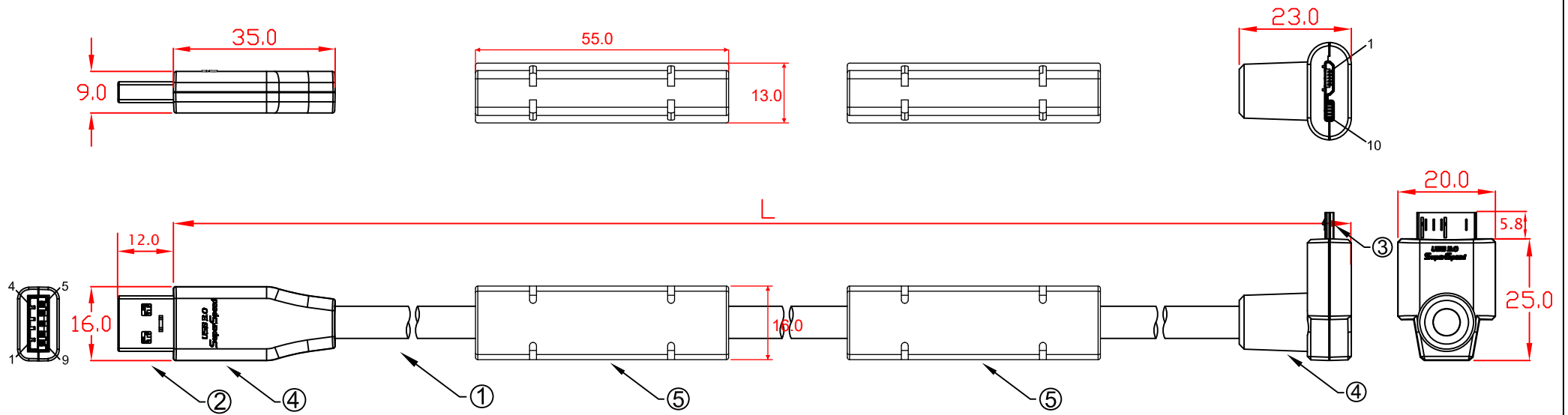

L:
 CBL-HFD3igMB-7mUA 7000mm±50mm
 CBL-HFD3igMB-8mUA 8000mm±50mm
 CBL-HFD3igMB-9mUA 9000mm+50mm

No	MATERIALS LIST:
1.	CABLE:UL20236 (2x(2x28AWG)+2x(2x28AWG)C) OD:7.0mm PUR JACKET COLOR:RED LILAC
2.	CONNECTOR:USB 3.0 A/M, 9P, BLUE INSULATOR SOLDER TYPE, NICKEL PLATED SHELL
3.	CONNECTOR:USB 3.0 MicroB/M, 10P, BLACK INSULATOR SOLDER TYPE, NICKEL PLATED SHELL
4.	ABS ASSEMBLY HOUSING, BLACK COLOR
5.	PVC MOLDED HOUSING, BLACK COLOR

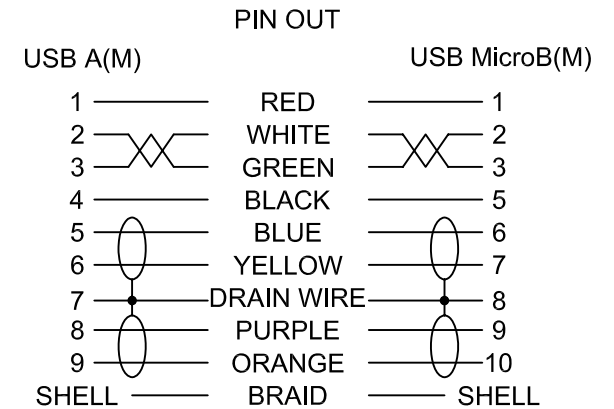

Jargy part no.	Client part no.	Approved	SCALE	UNIT
CBL-HFD3igMB-xmUA				mm
Drawing Name		Drawn	Date	REV.
USB 3.0 A to Micro-B Cable M/M				1.0

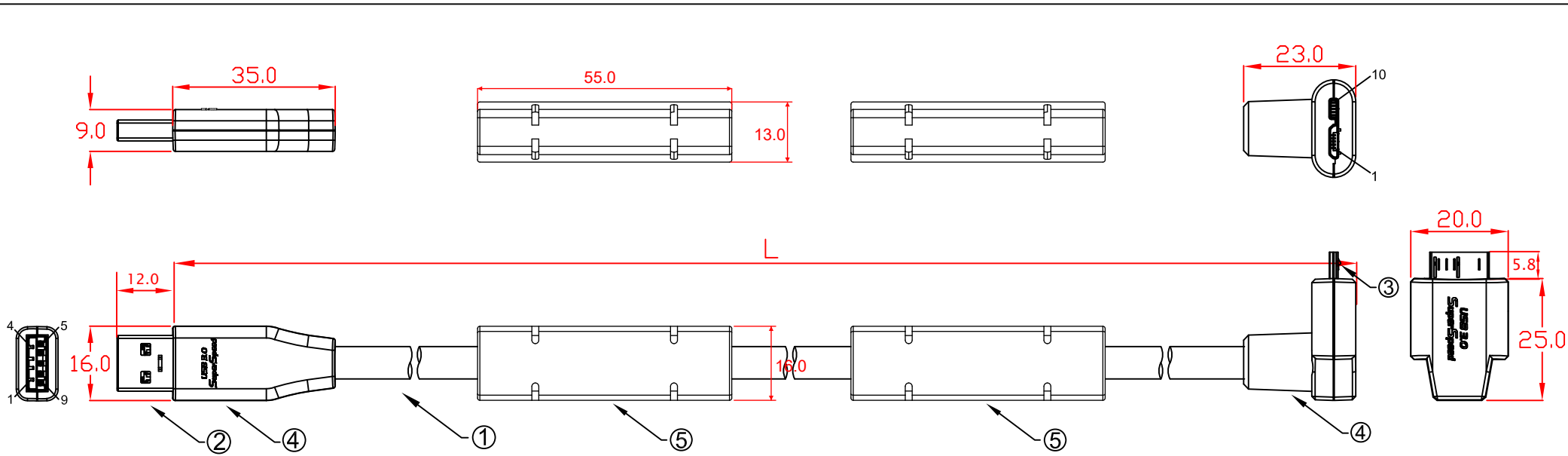

L:
 CBL-HFD3igMB-7mDA 7000mm±50mm
 CBL-HFD3igMB-8mDA 8000mm±50mm
 CBL-HFD3igMB-9mDA 9000mm+50mm

No	MATERIALS LIST:
1.	CABLE:UL20236 (2x(2x28AWG)+2x(2x28AWG)C) OD:7.0mm PUR JACKET COLOR:RED LILAC
2.	CONNECTOR:USB 3.0 A/M, 9P, BLUE INSULATOR SOLDER TYPE, NICKEL PLATED SHELL
3.	CONNECTOR:USB 3.0 MicroB/M, 10P, BLACK INSULATOR SOLDER TYPE, NICKEL PLATED SHELL
4.	ABS ASSEMBLY HOUSING, BLACK COLOR
5.	PVC MOLDED HOUSING, BLACK COLOR

PIN OUT	
USB A(M)	USB MicroB(M)
1 ———	RED ——— 1
2 ———	WHITE ——— 2
3 ———	GREEN ——— 3
4 ———	BLACK ——— 5
5 ———	BLUE ——— 6
6 ———	YELLOW ——— 7
7 ———	DRAIN WIRE ——— 8
8 ———	PURPLE ——— 9
9 ———	ORANGE ——— 10
SHELL ———	BRAID ——— SHELL

Jargy part no.	Client part no.	Approved	SCALE	UNIT
CBL-HFD3igMB-xmDA				mm
Drawing Name		Drawn	Date	REV.
USB 3.0 A to Micro-B Cable M/M				1.0

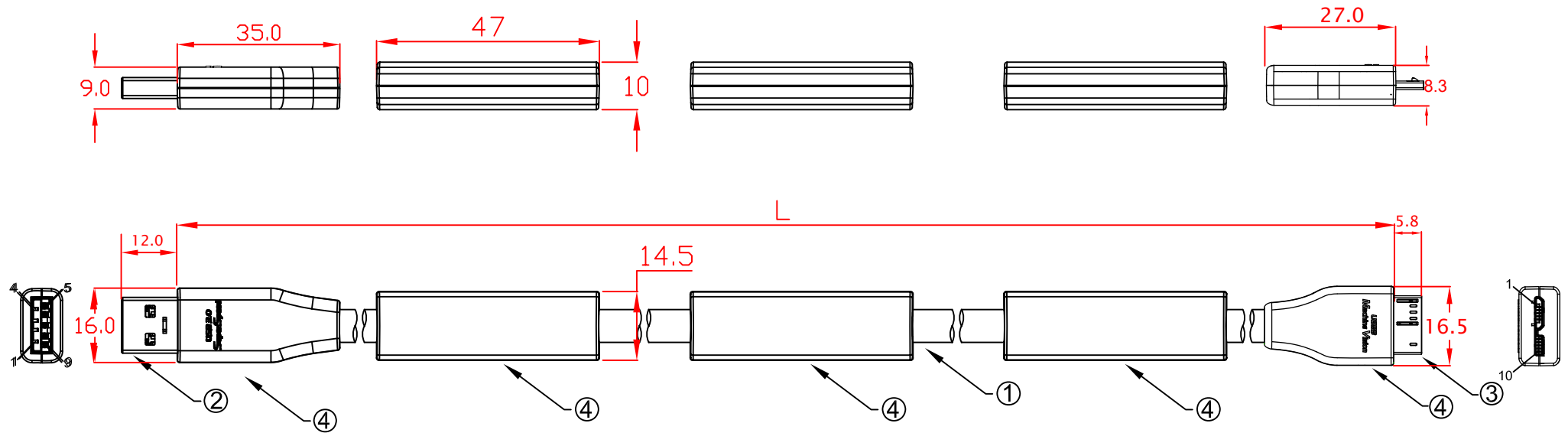

L:
 CBL-HFD3igMB-10m 10000mm±50mm
 CBL-HFD3igMB-11m 11000mm±50mm
 CBL-HFD3igMB-12m 12000mm±50mm

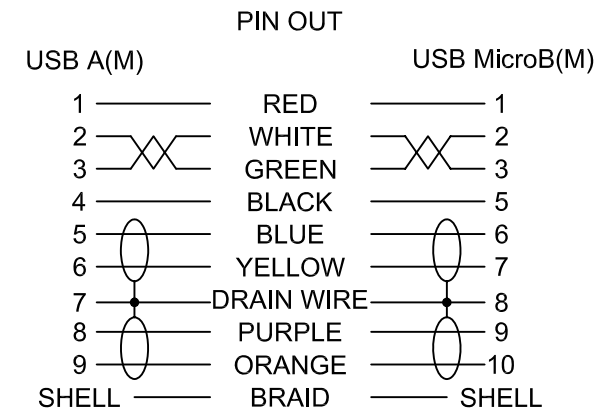

No	MATERIALS LIST:
1.	CABLE:UL20236 (2x(2x28AWG)+2x(2x28AWG)C) OD:7.0mm PUR JACKET COLOR:RED LILAC
2.	CONNECTOR:USB 3.0 A/M, 9P, BLUE INSULATOR SOLDER TYPE, NICKEL PLATED SHELL
3.	CONNECTOR:USB 3.0 MicroB/M, 10P, BLACK INSULATOR SOLDER TYPE, NICKEL PLATED SHELL
4.	ABS ASSEMBLY HOUSING, BLACK COLOR

Jargy part no.	Client part no.	Approved	SCALE	UNIT
CBL-HFD3igMB-xm				mm
Drawing Name		Drawn	Date	REV.
USB 3.0 A to Micro-B Cable M/M				1.0



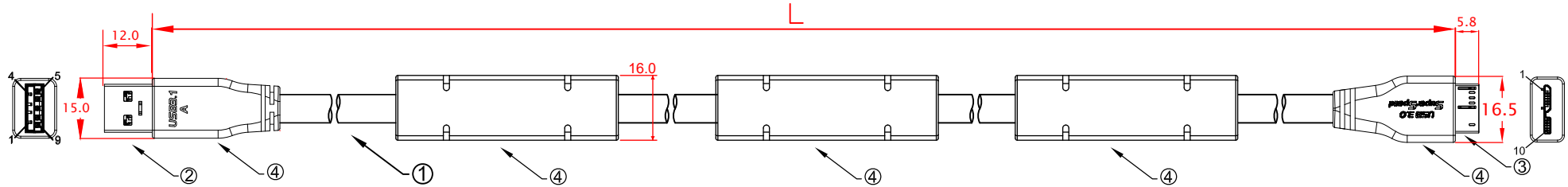
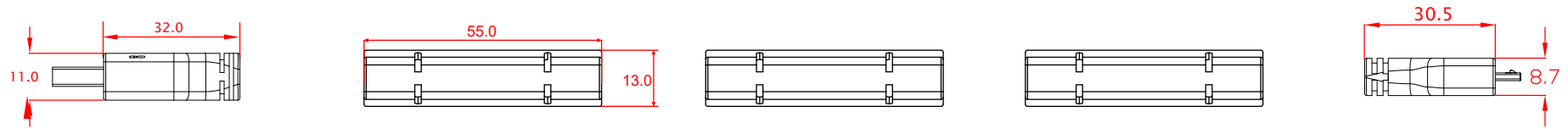

L:
 CBL-HFD3igMB-10m 10000mm±50mm
 CBL-HFD3igMB-11m 11000mm±50mm
 CBL-HFD3igMB-12m 12000mm±50mm

PIN OUT

USB A(M)

USB MicroB(M)

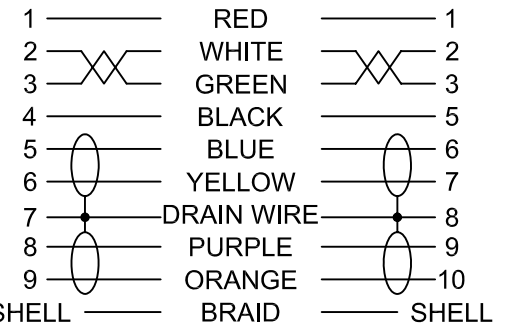

No	MATERIALS LIST:
1.	CABLE:UL20236 (2x(2x28AWG)+2x(2x28AWG)C) OD:7.0mm PUR JACKET COLOR:RED LILAC
2.	CONNECTOR:USB 3.0 A/M, 9P, BLUE INSULATOR SOLDER TYPE, NICKEL PLATED SHELL
3.	CONNECTOR:USB 3.0 MicroB/M, 10P, BLACK INSULATOR SOLDER TYPE, NICKEL PLATED SHELL
4.	PVC MOLDED HOUSING, BLACK COLOR
5.	
6.	

Jargy part no.	Client part no.	Approved	SCALE	UNIT
CBL-HFD3igMB-xm				mm
Drawing Name		Drawn	Date	REV.
USB 3.0 A to Micro-B Cable M/M				1.0

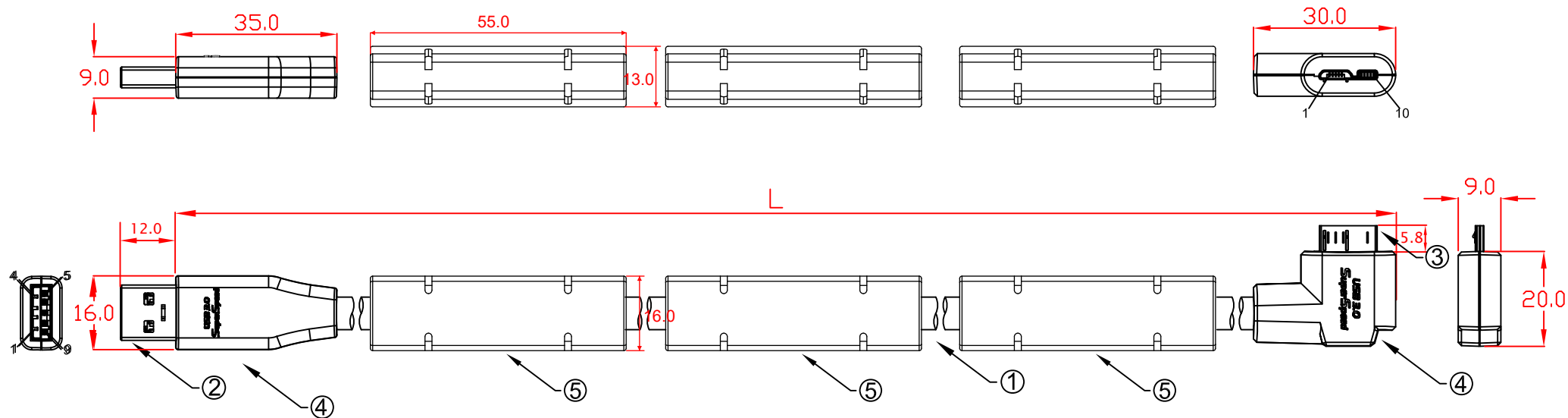

L:
 CBL-HFD3igMB-10mLA 10000mm±50mm
 CBL-HFD3igMB-11mLA 11000mm±50mm
 CBL-HFD3igMB-12mLA 12000mm±50mm

PIN OUT	
USB A(M)	USB MicroB(M)
1 ———	1 ———
2 ———	2 ———
3 ———	3 ———
4 ———	5 ———
5 ———	6 ———
6 ———	7 ———
7 ———	8 ———
8 ———	9 ———
9 ———	10 ———
SHELL ———	SHELL ———

No	MATERIALS LIST:
1.	CABLE:UL20236 (2x(2x28AWG)+2x(2x28AWG)C) OD:7.0mm PUR JACKET COLOR:RED LILAC
2.	CONNECTOR:USB 3.0 A/M, 9P, BLUE INSULATOR SOLDER TYPE, NICKEL PLATED SHELL
3.	CONNECTOR:USB 3.0 MicroB/M, 10P, BLACK INSULATOR SOLDER TYPE, NICKEL PLATED SHELL
4.	ABS ASSEMBLY HOUSING, BLACK COLOR
5.	PVC MOLDED HOUSING, BLACK COLOR

Jargy part no.	Client part no.	Approved	SCALE	UNIT
CBL-HFD3igMB-xmLA				mm
Drawing Name		Drawn	Date	REV.
USB 3.0 A to Micro-B Cable M/M				1.0

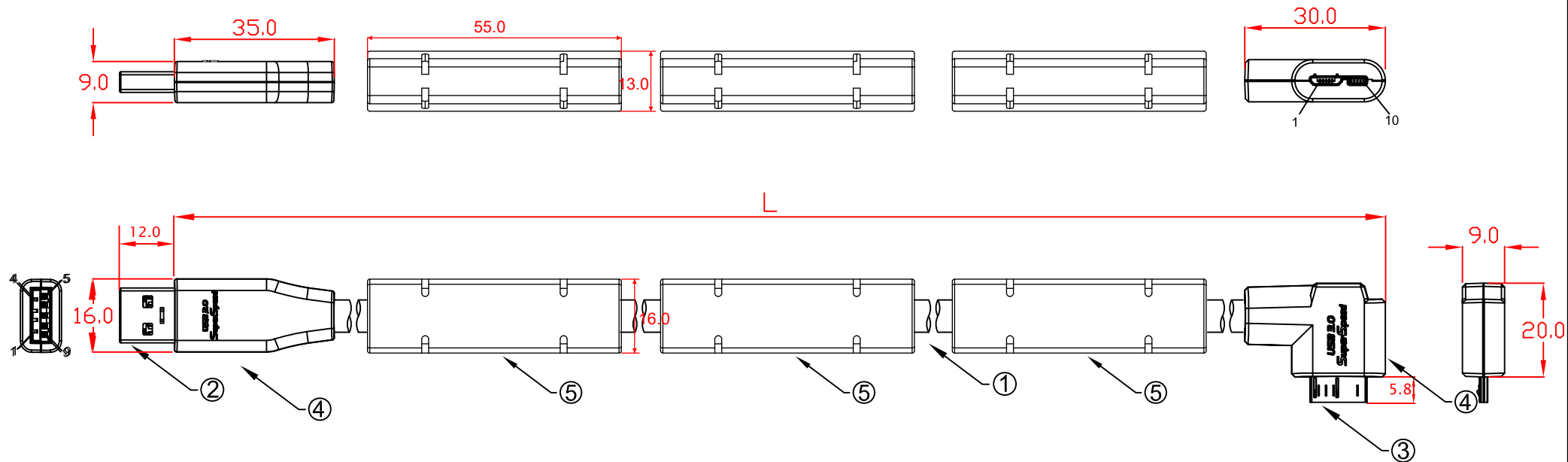

L:
 CBL-HFD3igMB-10mRA 10000mm±50mm
 CBL-HFD3igMB-11mRA 11000mm±50mm
 CBL-HFD3igMB-12mRA 12000mm±50mm

PIN OUT		
USB A(M)		USB MicroB(M)
1 ———	RED	1 ———
2 — X —	WHITE	2 — X —
3 — X —	GREEN	3 — X —
4 ———	BLACK	5 ———
5 — O —	BLUE	6 — O —
6 — O —	YELLOW	7 — O —
7 — ● —	DRAIN WIRE	8 — ● —
8 — O —	PURPLE	9 — O —
9 — O —	ORANGE	10 — O —
SHELL ———	BRAID	SHELL ———

No	MATERIALS LIST:
1.	CABLE:UL20236 (2x(2x28AWG)+2x(2x28AWG)C) OD:7.0mm PUR JACKET COLOR:RED LILAC
2.	CONNECTOR:USB 3.0 A/M, 9P, BLUE INSULATOR SOLDER TYPE, NICKEL PLATED SHELL
3.	CONNECTOR:USB 3.0 MicroB/M, 10P, BLACK INSULATOR SOLDER TYPE, NICKEL PLATED SHELL
4.	ABS ASSEMBLY HOUSING, BLACK COLOR
5.	PVC MOLDED HOUSING, BLACK COLOR

Jargy part no.	Client part no.	Approved	SCALE	UNIT
CBL-HFD3igMB-xmRA				mm
Drawing Name		Drawn	Date	REV.
USB 3.0 A to Micro-B Cable M/M				1.0

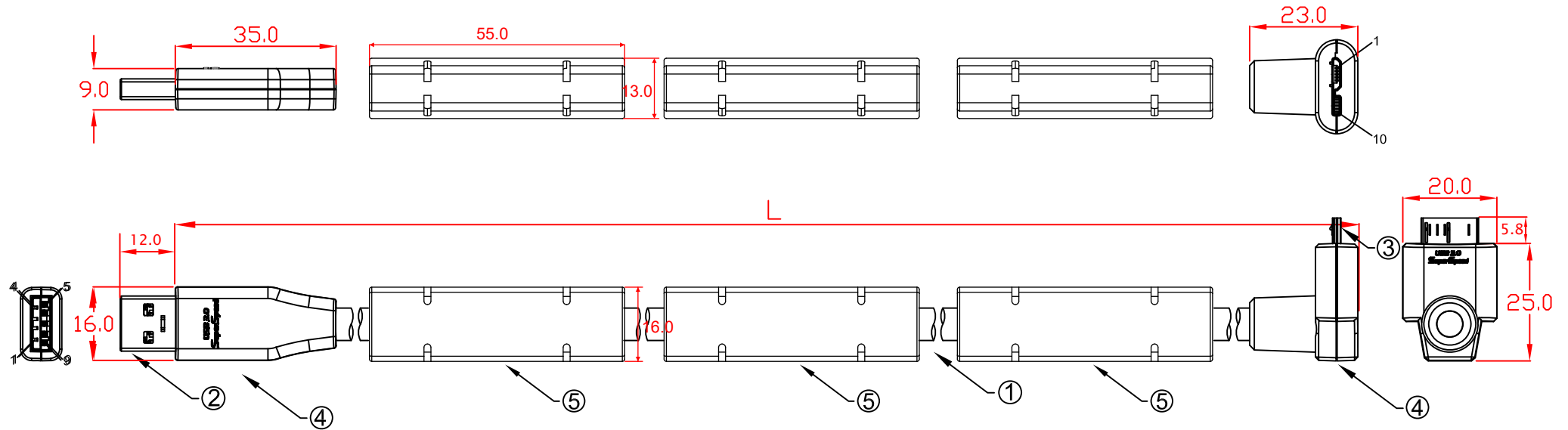

L:
 CBL-HFD3igMB-10mUA 10000mm±50mm
 CBL-HFD3igMB-11mUA 11000mm±50mm
 CBL-HFD3igMB-12mUA 12000mm±50mm

USB A(M)		PIN OUT	USB MicroB(M)	
1	—	RED	1	—
2	—	WHITE	2	—
3	—	GREEN	3	—
4	—	BLACK	5	—
5	—	BLUE	6	—
6	—	YELLOW	7	—
7	—	DRAIN WIRE	8	—
8	—	PURPLE	9	—
9	—	ORANGE	10	—
SHELL	—	BRAID	SHELL	—

No	MATERIALS LIST:
1.	CABLE:UL20236 (2x(2x28AWG)+2x(2x28AWG)C) OD:7.0mm PUR JACKET COLOR:RED LILAC
2.	CONNECTOR:USB 3.0 A/M, 9P, BLUE INSULATOR SOLDER TYPE, NICKEL PLATED SHELL
3.	CONNECTOR:USB 3.0 MicroB/M, 10P, BLACK INSULATOR SOLDER TYPE, NICKEL PLATED SHELL
4.	ABS ASSEMBLY HOUSING, BLACK COLOR
5.	PVC MOLDED HOUSING, BLACK COLOR

Jargy part no.	Client part no.	Approved	SCALE	UNIT
CBL-HFD3igMB-xmUA				mm
Drawing Name		Drawn	Date	REV.
USB 3.0 A to Micro-B Cable M/M				1.0

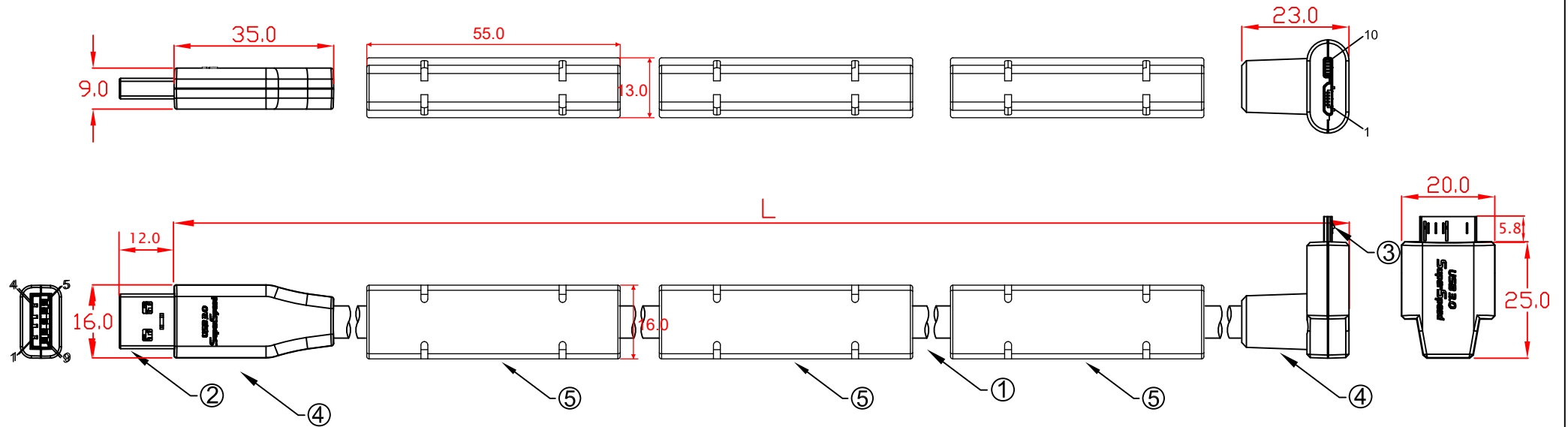

L:
 CBL-HFD3igMB-10mDA 10000mm±50mm
 CBL-HFD3igMB-11mDA 11000mm±50mm
 CBL-HFD3igMB-12mDA 12000mm±50mm

USB A(M)		PIN OUT	USB MicroB(M)	
1	—	RED	—	1
2	—	WHITE	—	2
3	—	GREEN	—	3
4	—	BLACK	—	5
5	—	BLUE	—	6
6	—	YELLOW	—	7
7	—	DRAIN WIRE	—	8
8	—	PURPLE	—	9
9	—	ORANGE	—	10
	SHELL	BRAID		SHELL

No	MATERIALS LIST:
1.	CABLE:UL20236 (2x(2x28AWG)+2x(2x28AWG)C) OD:7.0mm PUR JACKET COLOR:RED LILAC
2.	CONNECTOR:USB 3.0 A/M, 9P, BLUE INSULATOR SOLDER TYPE, NICKEL PLATED SHELL
3.	CONNECTOR:USB 3.0 MicroB/M, 10P, BLACK INSULATOR SOLDER TYPE, NICKEL PLATED SHELL
4.	ABS ASSEMBLY HOUSING, BLACK COLOR
5.	PVC MOLDED HOUSING, BLACK COLOR

Jargy part no.	Client part no.	Approved	SCALE	UNIT
CBL-HFD3igMB-xmDA				mm
Drawing Name		Drawn	Date	REV.
USB 3.0 A to Micro-B Cable M/M				1.0

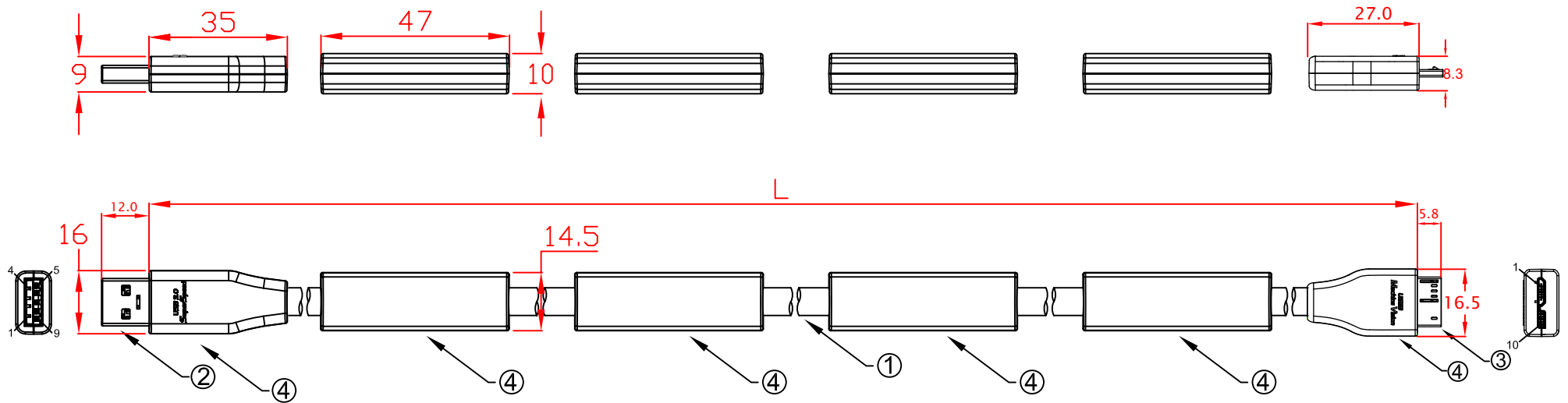

L:
 CBL-HFD3igMB-13m 13000mm±50mm
 CBL-HFD3igMB-14m 14000mm±50mm
 CBL-HFD3igMB-15m 15000mm±50mm

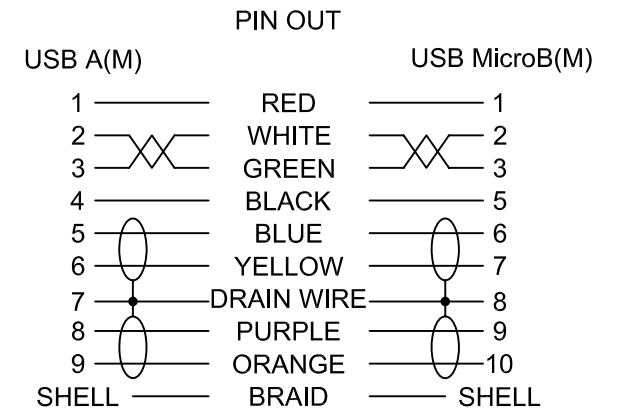

No	MATERIALS LIST:
1.	CABLE:UL20236 (2x(2x28AWG)+2x(2x28AWG)C) OD:7.0mm PUR JACKET COLOR:RED LILAC
2.	CONNECTOR:USB 3.0 A/M, 9P, BLUE INSULATOR SOLDER TYPE, NICKEL PLATED SHELL
3.	CONNECTOR:USB 3.0 MicroB/M, 10P, BLACK INSULATOR SOLDER TYPE, NICKEL PLATED SHELL
4.	ABS ASSEMBLY HOUSING, BLACK COLOR

Jargy part no.	Client part no.	Approved	SCALE	UNIT
CBL-HFD3igCMB-xm				mm
Drawing Name		Drawn	Date	REV.
USB 3.0 A to Micro-B Cable M/M				1.0

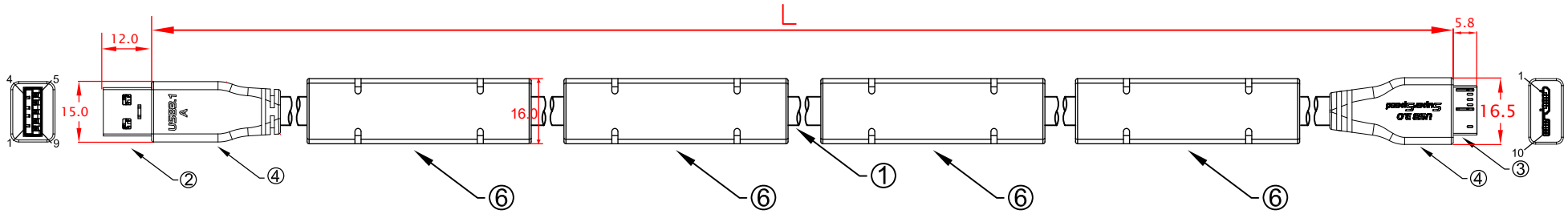
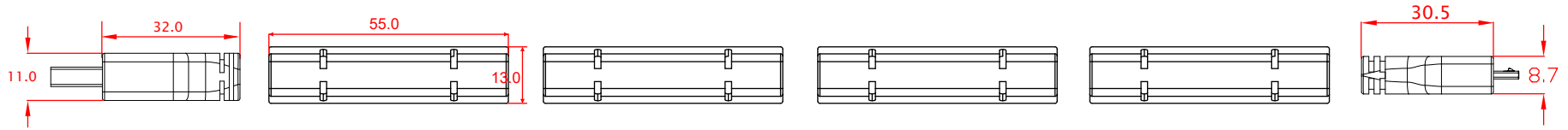

L:
 CBL-HFD3igMB-13m 13000mm±50mm
 CBL-HFD3igMB-14m 14000mm±50mm
 CBL-HFD3igMB-15m 15000mm±50mm

PIN OUT

USB A(M)

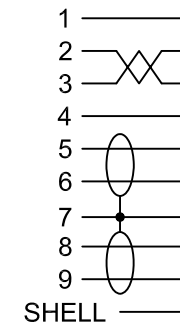

USB MicroB(M)

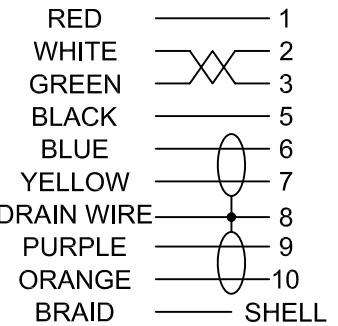

No	MATERIALS LIST:
1.	CABLE:UL20236 (2x(2x28AWG)+2x(2x28AWG)C) OD:7.0mm PUR JACKET COLOR:RED LILAC
2.	CONNECTOR:USB 3.0 A/M, 9P, BLUE INSULATOR SOLDER TYPE, NICKEL PLATED SHELL
3.	CONNECTOR:USB 3.0 MicroB/M, 10P, BLACK INSULATOR SOLDER TYPE, NICKEL PLATED SHELL
4.	PVC MOLDED HOUSING, BLACK COLOR
5.	
6.	

Jargy part no.	Client part no.	Approved	SCALE	UNIT
CBL-HFD3igMB-xm				mm
Drawing Name		Drawn	Date	REV.
USB 3.0 A to Micro-B Cable M/M				1.0

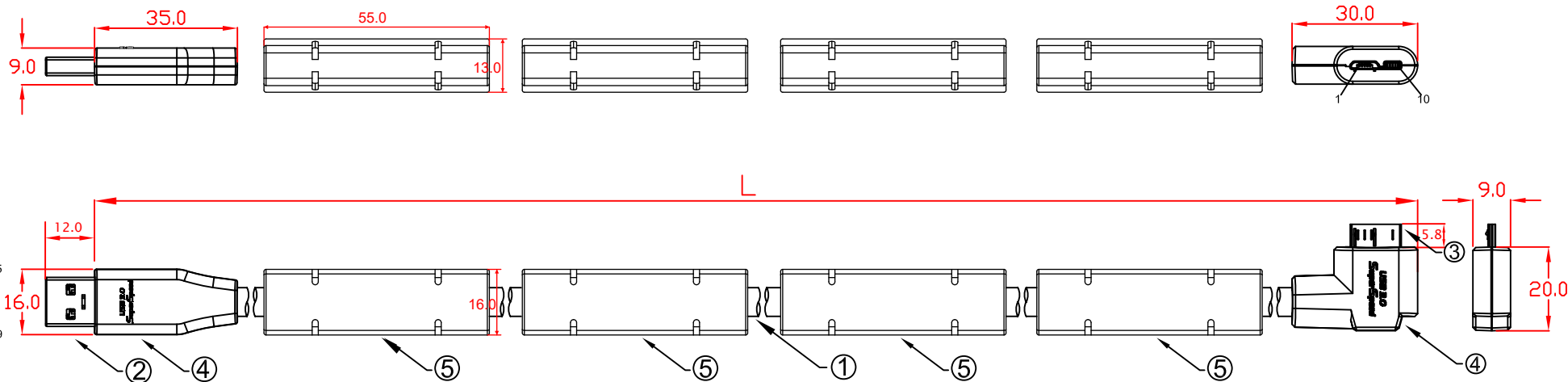

L:
 CBL-HFD3igMB-13mLA 13000mm±50mm
 CBL-HFD3igMB-14mLA 14000mm±50mm
 CBL-HFD3igMB-15mLA 15000mm±50mm

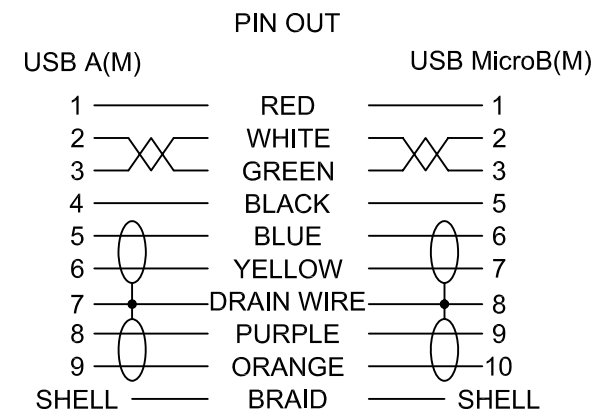

No	MATERIALS LIST:
1.	CABLE:UL20236 (2x(2x28AWG)+2x(2x28AWG)C) OD:7.0mm PUR JACKET COLOR:RED LILAC
2.	CONNECTOR:USB 3.0 A/M, 9P, BLUE INSULATOR SOLDER TYPE, NICKEL PLATED SHELL
3.	CONNECTOR:USB 3.0 MicroB/M, 10P, BLACK INSULATOR SOLDER TYPE, NICKEL PLATED SHELL
4.	ABS ASSEMBLY HOUSING, BLACK COLOR
5.	PVC MOLDED HOUSING, BLACK COLOR

Jargy part no.	Client part no.	Approved	SCALE	UNIT
CBL-HFD3igMB-xmLA				mm
Drawing Name		Drawn	Date	REV.
USB 3.0 A to Micro-B Cable M/M				1.0

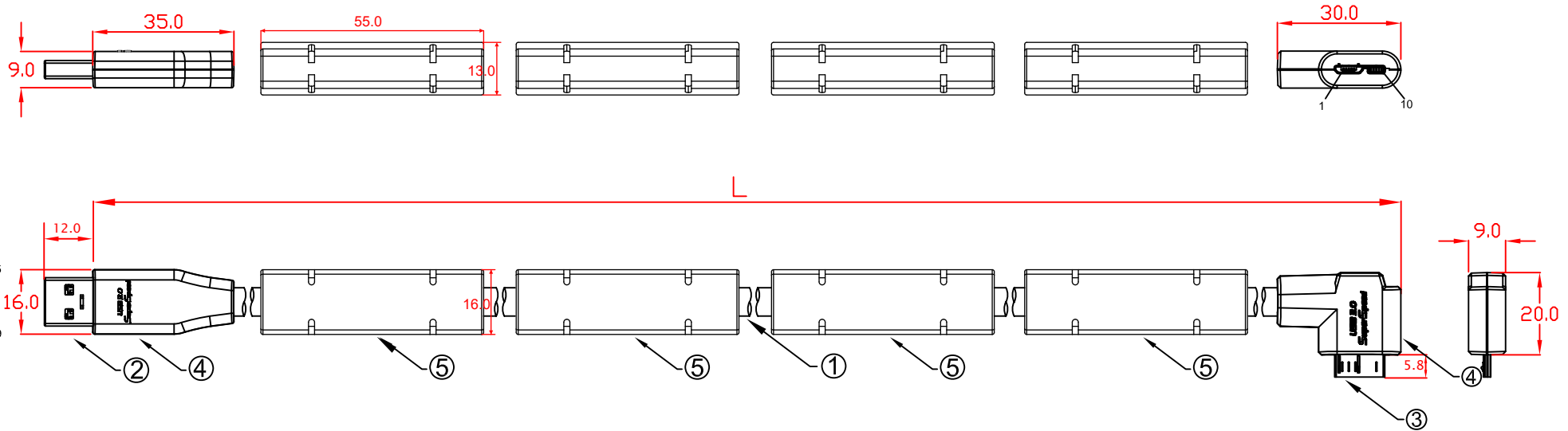

L:
 CBL-HFD3igMB-13mRA 13000mm±50mm
 CBL-HFD3igMB-14mRA 14000mm±50mm
 CBL-HFD3igMB-15mRA 15000mm±50mm

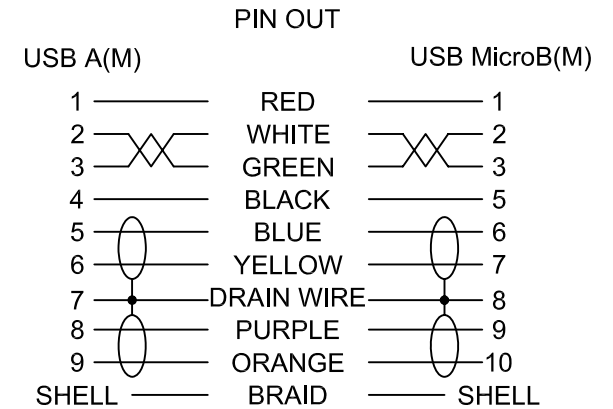

No	MATERIALS LIST:
1.	CABLE:UL20236 (2x(2x28AWG)+2x(2x28AWG)C) OD:7.0mm PUR JACKET COLOR:RED LILAC
2.	CONNECTOR:USB 3.0 A/M, 9P, BLUE INSULATOR SOLDER TYPE, NICKEL PLATED SHELL
3.	CONNECTOR:USB 3.0 MicroB/M, 10P, BLACK INSULATOR SOLDER TYPE, NICKEL PLATED SHELL
4.	ABS ASSEMBLY HOUSING, BLACK COLOR
5.	PVC MOLDED HOUSING, BLACK COLOR

Jargy part no.	Client part no.	Approved	SCALE	UNIT
CBL-HFD3igMB-xmRA				mm
Drawing Name		Drawn	Date	REV.
USB 3.0 A to Micro-B Cable M/M				1.0

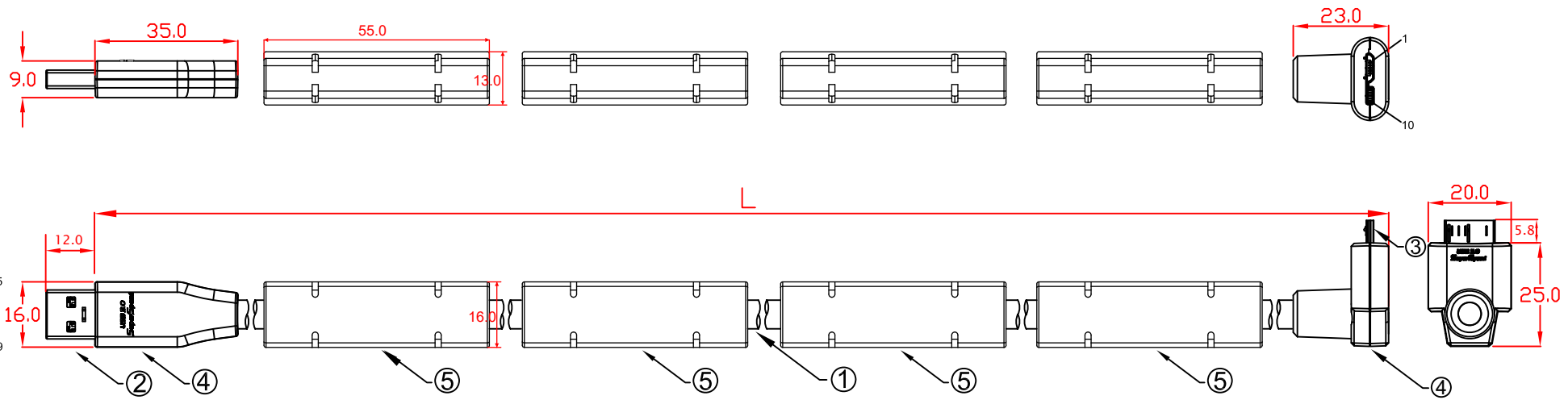

L:
 CBL-HFD3igMB-13mUA 13000mm±50mm
 CBL-HFD3igMB-14mUA 14000mm±50mm
 CBL-HFD3igMB-15mUA 15000mm±50mm

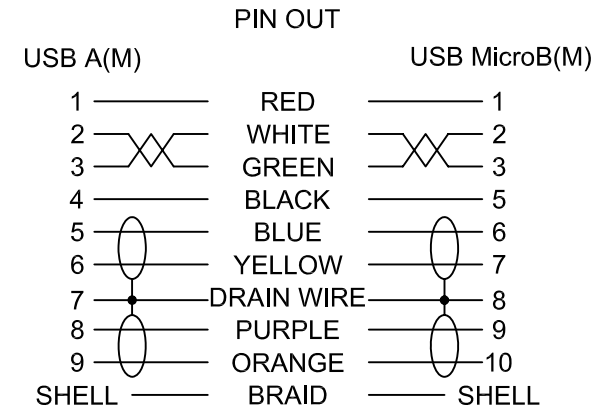

No	MATERIALS LIST:
1.	CABLE:UL20236 (2x(2x28AWG)+2x(2x28AWG)C) OD:7.0mm PUR JACKET COLOR:RED LILAC
2.	CONNECTOR:USB 3.0 A/M, 9P, BLUE INSULATOR SOLDER TYPE, NICKEL PLATED SHELL
3.	CONNECTOR:USB 3.0 MicroB/M, 10P, BLACK INSULATOR SOLDER TYPE, NICKEL PLATED SHELL
4.	ABS ASSEMBLY HOUSING, BLACK COLOR
5.	PVC MOLDED HOUSING, BLACK COLOR

Jargy part no.	Client part no.	Approved	SCALE	UNIT
CBL-HFD3igMB-xmUA				mm
Drawing Name		Drawn	Date	REV.
USB 3.0 A to Micro-B Cable M/M				1.0

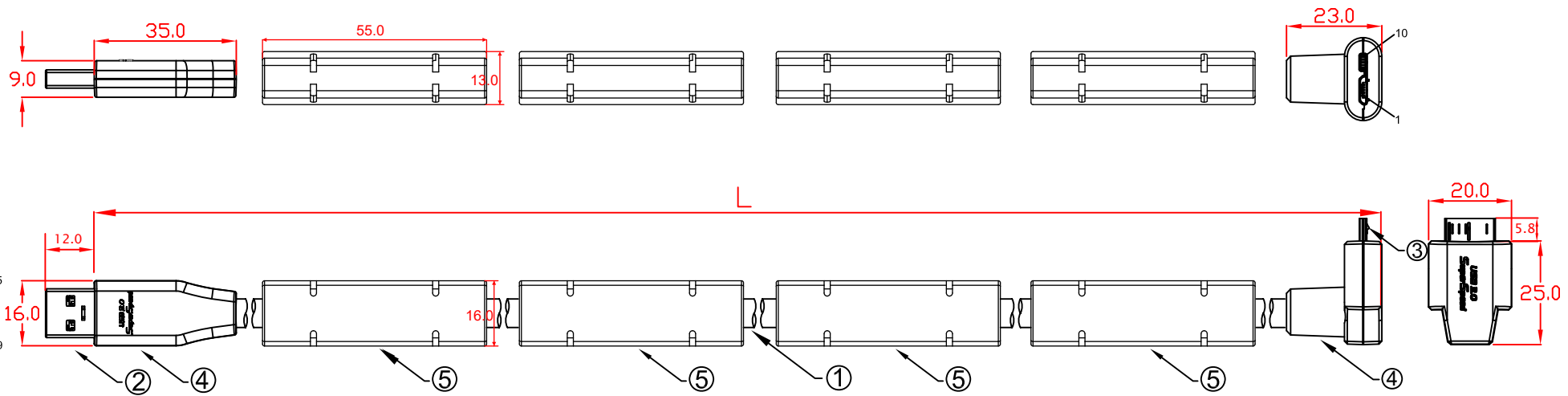

L:
 CBL-HFD3igMB-13mDA 13000mm±50mm
 CBL-HFD3igMB-14mDA 14000mm±50mm
 CBL-HFD3igMB-15mDA 15000mm±50mm

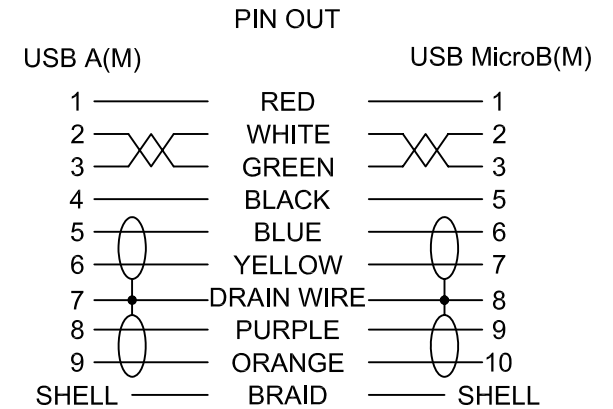

No	MATERIALS LIST:
1.	CABLE:UL20236 (2x(2x28AWG)+2x(2x28AWG)C) OD:7.0mm PUR JACKET COLOR:RED LILAC
2.	CONNECTOR:USB 3.0 A/M, 9P, BLUE INSULATOR SOLDER TYPE, NICKEL PLATED SHELL
3.	CONNECTOR:USB 3.0 MicroB/M, 10P, BLACK INSULATOR SOLDER TYPE, NICKEL PLATED SHELL
4.	ABS ASSEMBLY HOUSING, BLACK COLOR
5.	PVC MOLDED HOUSING, BLACK COLOR

Jargy part no.	Client part no.	Approved	SCALE	UNIT
CBL-HFD3igMB-xmDA				mm
Drawing Name		Drawn	Date	REV.
USB 3.0 A to Micro-B Cable M/M				1.0

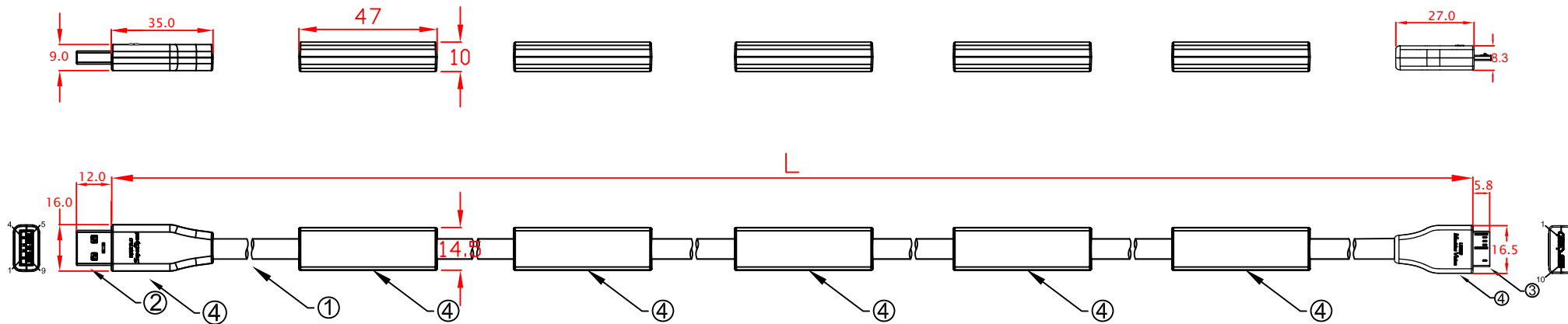

- L:
- CBL-HFD3igMB-16m 16000mm±50mm
 - CBL-HFD3igMB-17m 17000mm±50mm
 - CBL-HFD3igMB-18m 18000mm±50mm
 - CBL-HFD3igMB-19m 19000mm±50mm
 - CBL-HFD3igMB-20m 20000mm±50mm

No	MATERIALS LIST:
1.	CABLE:UL20236 (2x(2x28AWG)+2x(2x28AWG)C) OD:7.0mm PUR JACKET COLOR:RED LILAC
2.	CONNECTOR:USB 3.0 A/M, 9P, BLUE INSULATOR SOLDER TYPE, NICKEL PLATED SHELL
3.	CONNECTOR:USB 3.0 MicroB/M, 10P, BLACK INSULATOR SOLDER TYPE, NICKEL PLATED SHELL
4.	ABS ASSEMBLY HOUSING, BLACK COLOR
5.	

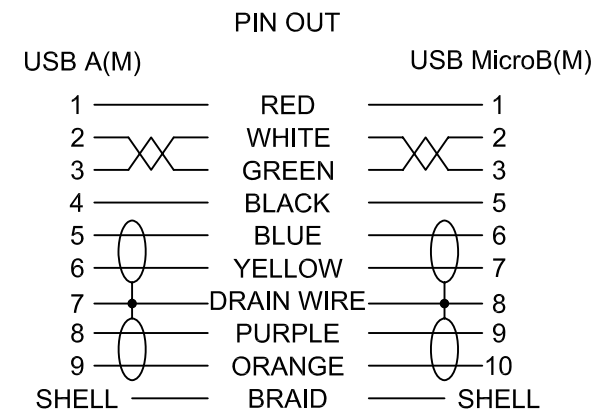

Jargy part no.	Client part no.	Approved	SCALE	UNIT
CBL-HFD3igMB-xm				mm
Drawing Name		Drawn	Date	REV.
USB 3.0 A to Micro-B Cable M/M				1.0

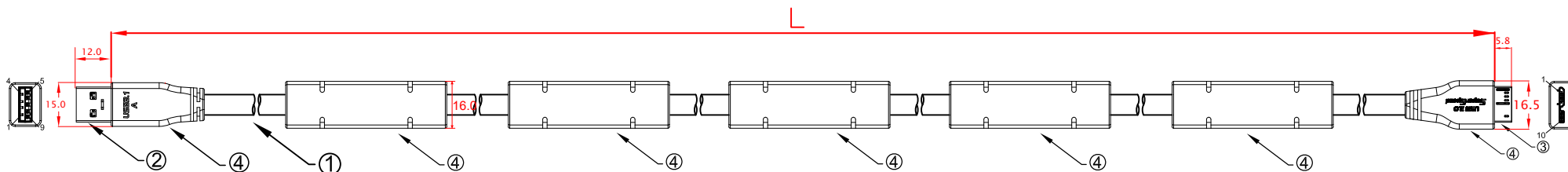
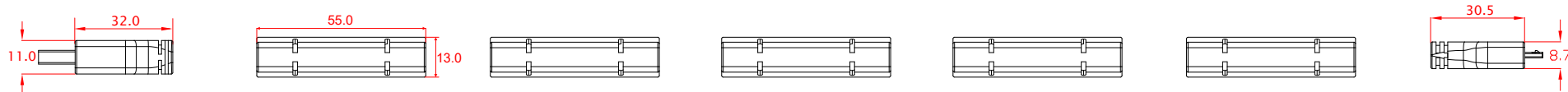

- L:
- CBL-HFD3igMB-16m 16000mm±50mm
 - CBL-HFD3igMB-17m 17000mm±50mm
 - CBL-HFD3igMB-18m 18000mm±50mm
 - CBL-HFD3igMB-19m 19000mm±50mm
 - CBL-HFD3igMB-20m 20000mm±50mm

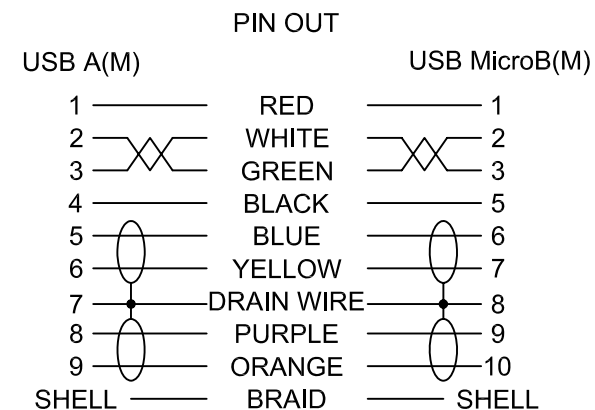

No	MATERIALS LIST:
1.	CABLE:UL20236 (2x(2x28AWG)+2x(2x28AWG)C) OD:7.0mm PUR JACKET COLOR:RED LILAC
2.	CONNECTOR:USB 3.0 A/M, 9P, BLUE INSULATOR SOLDER TYPE, NICKEL PLATED SHELL
3.	CONNECTOR:USB 3.0 MicroB/M, 10P, BLACK INSULATOR SOLDER TYPE, NICKEL PLATED SHELL
4.	PVC MOLDED HOUSING, BLACK COLOR
5.	
6.	

Jargy part no.	Client part no.	Approved	SCALE	UNIT
CBL-HFD3igMB-xm				mm
Drawing Name		Drawn	Date	REV.
USB 3.0 A to Micro-B Cable M/M				1.0

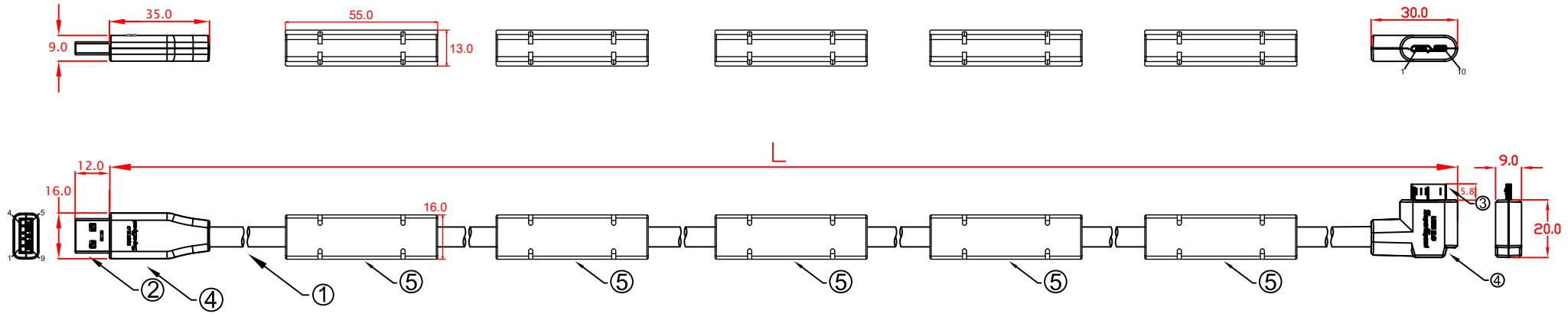

- L:
- CBL-HFD3igMB-16mLA 16000mm±50mm
 - CBL-HFD3igMB-17mLA 17000mm±50mm
 - CBL-HFD3igMB-18mLA 18000mm±50mm
 - CBL-HFD3igMB-19mLA 19000mm±50mm
 - CBL-HFD3igMB-20mLA 20000mm±50mm

No	MATERIALS LIST:
1.	CABLE:UL20236 (2x(2x28AWG)+2x(2x28AWG)C) OD:7.0mm PUR JACKET COLOR:RED LILAC
2.	CONNECTOR:USB 3.0 A/M, 9P, BLUE INSULATOR SOLDER TYPE, NICKEL PLATED SHELL
3.	CONNECTOR:USB 3.0 MicroB/M, 10P, BLACK INSULATOR SOLDER TYPE, NICKEL PLATED SHELL
4.	ABS ASSEMBLY HOUSING, BLACK COLOR
5.	PVC MOLDED HOUSING, BLACK COLOR

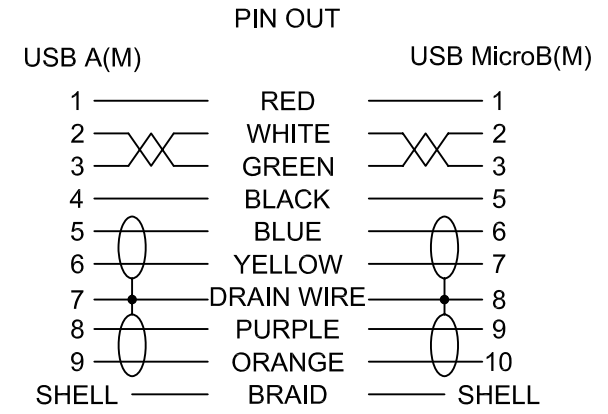

Jargy part no.	Client part no.	Approved	SCALE	UNIT
CBL-HFD3igMB-xmLA				mm
Drawing Name		Drawn	Date	REV.
USB 3.0 A to Micro-B Cable M/M				1.0

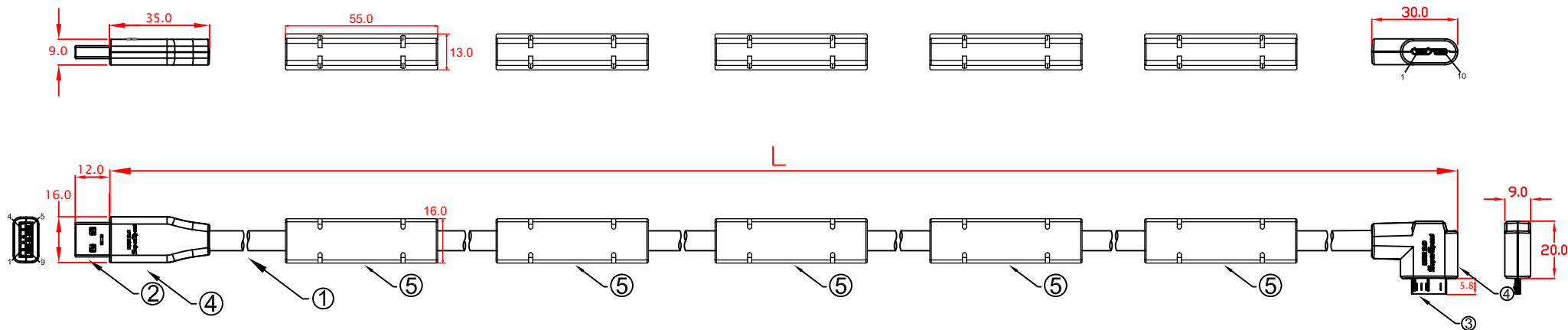

- L:
- CBL-HFD3igMB-16mRA 16000mm±50mm
 - CBL-HFD3igMB-17mRA 17000mm±50mm
 - CBL-HFD3igMB-18mRA 18000mm±50mm
 - CBL-HFD3igMB-19mRA 19000mm±50mm
 - CBL-HFD3igMB-20mRA 20000mm±50mm

No	MATERIALS LIST:
1.	CABLE:UL20236 (2x(2x28AWG)+2x(2x28AWG)C) OD:7.0mm PUR JACKET COLOR:RED LILAC
2.	CONNECTOR:USB 3.0 A/M, 9P, BLUE INSULATOR SOLDER TYPE, NICKEL PLATED SHELL
3.	CONNECTOR:USB 3.0 MicroB/M, 10P, BLACK INSULATOR SOLDER TYPE, NICKEL PLATED SHELL
4.	ABS ASSEMBLY HOUSING, BLACK COLOR
5.	PVC MOLDED HOUSING, BLACK COLOR

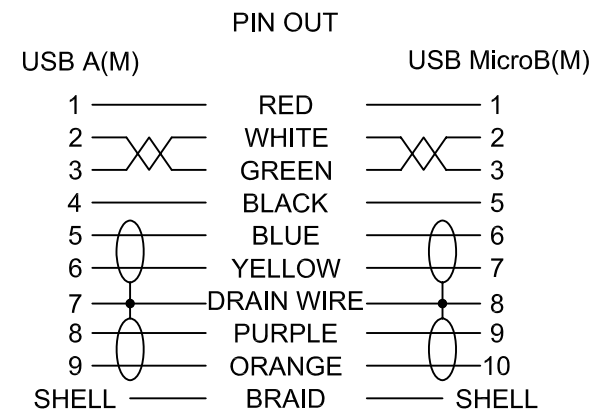

Jargy part no.	Client part no.	Approved	SCALE	UNIT
CBL-HFD3igMB-xmRA				mm
Drawing Name		Drawn	Date	REV.
USB 3.0 A to Micro-B Cable M/M				1.0

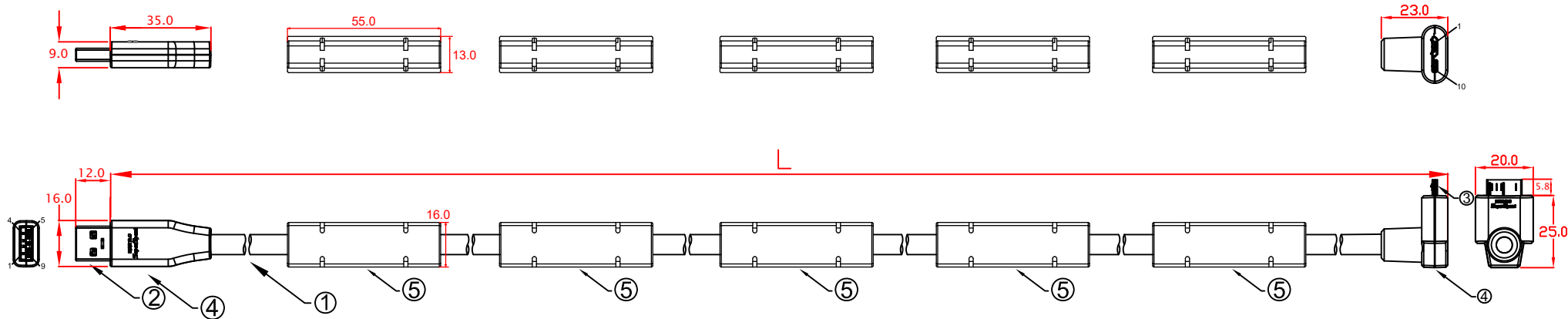

L:

CBL-HFD3igMB-16mUA	16000mm±50mm
CBL-HFD3igMB-17mUA	17000mm±50mm
CBL-HFD3igMB-18mUA	18000mm±50mm
CBL-HFD3igMB-19mUA	19000mm±50mm
CBL-HFD3igMB-20mUA	20000mm±50mm

No	MATERIALS LIST:
1.	CABLE:UL20236 (2x(2x28AWG)+2x(2x28AWG)C) OD:7.0mm PUR JACKET COLOR:RED LILAC
2.	CONNECTOR:USB 3.0 A/M, 9P, BLUE INSULATOR SOLDER TYPE, NICKEL PLATED SHELL
3.	CONNECTOR:USB 3.0 MicroB/M, 10P, BLACK INSULATOR SOLDER TYPE, NICKEL PLATED SHELL
4.	ABS ASSEMBLY HOUSING, BLACK COLOR
5.	PVC MOLDED HOUSING, BLACK COLOR

PIN OUT		
USB A(M)		USB MicroB(M)
1 ———	RED	———— 1
2 ———	WHITE	———— 2
3 ———	GREEN	———— 3
4 ———	BLACK	———— 5
5 ———	BLUE	———— 6
6 ———	YELLOW	———— 7
7 ———	DRAIN WIRE	———— 8
8 ———	PURPLE	———— 9
9 ———	ORANGE	———— 10
SHELL ———	BRAID	———— SHELL

Jargy part no.	Client part no.	Approved	SCALE	UNIT
CBL-HFD3igMB-xmUA				mm
Drawing Name		Drawn	Date	REV.
USB 3.0 A to Micro-B Cable M/M				1.0

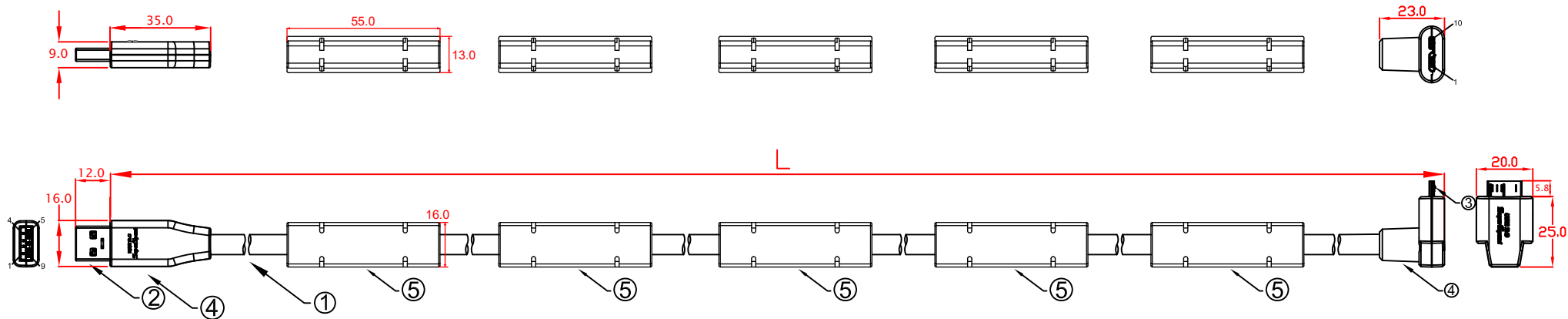

- L:
- CBL-HFD3igMB-16mDA 16000mm±50mm
 - CBL-HFD3igMB-17mDA 17000mm±50mm
 - CBL-HFD3igMB-18mDA 18000mm±50mm
 - CBL-HFD3igMB-19mDA 19000mm±50mm
 - CBL-HFD3igMB-20mDA 20000mm±50mm

No	MATERIALS LIST:
1.	CABLE:UL20236 (2x(2x28AWG)+2x(2x28AWG)C) OD:7.0mm PUR JACKET COLOR:RED LILAC
2.	CONNECTOR:USB 3.0 A/M, 9P, BLUE INSULATOR SOLDER TYPE, NICKEL PLATED SHELL
3.	CONNECTOR:USB 3.0 MicroB/M, 10P, BLACK INSULATOR SOLDER TYPE, NICKEL PLATED SHELL
4.	ABS ASSEMBLY HOUSING, BLACK COLOR
5.	PVC MOLDED HOUSING, BLACK COLOR

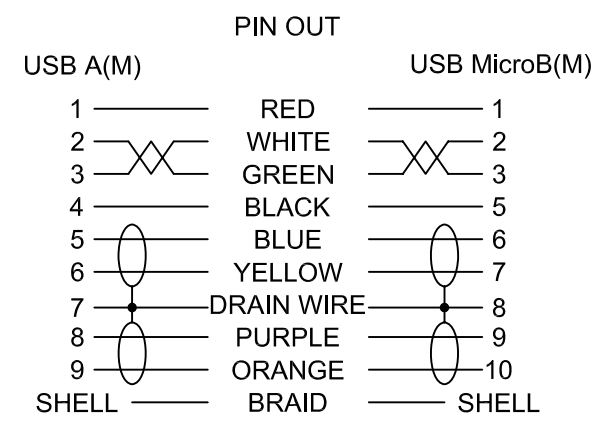

Jargy part no.	Client part no.	Approved	SCALE	UNIT
CBL-HFD3igMB-xmDA				mm
Drawing Name		Drawn	Date	REV.
USB 3.0 A to Micro-B Cable M/M				1.0